



---

# ST15 & ST10 Stingray ARCHIVE BOOK

## 15 ' Flex Wing - 4 Gearbox Model

S/N ST15-C31200557203 (Jan. 2002 )

to  
S/N ST15-Current

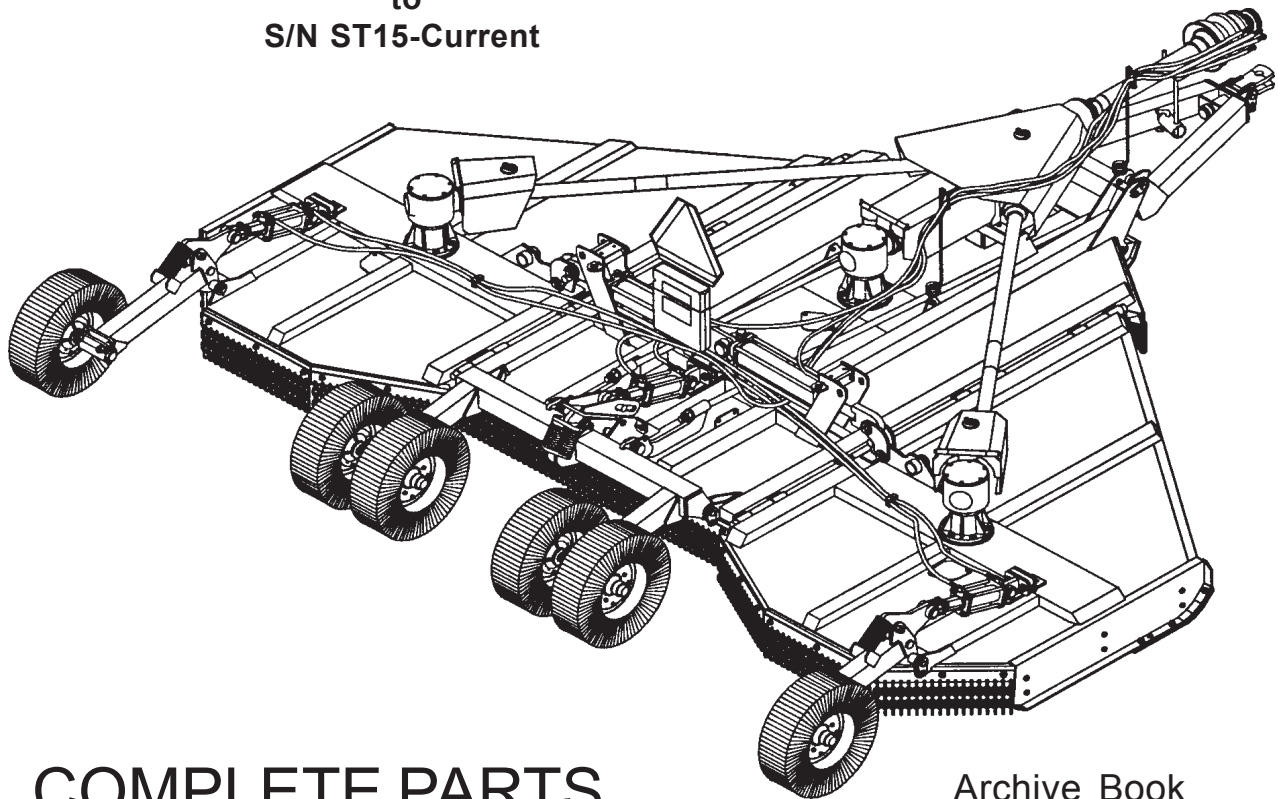

### COMPLETE PARTS LISTING

Archive Book  
Part No.  
02980337

---

ALAMO INDUSTRIAL

1502 E. Walnut  
Seguin, Texas 78155  
830-372-3551

2004 Edition Rev 01-09

© 2004 Alamo Group Inc.



# Alamo Industrial (Terrain King) 15 foot Flex Wing Mowers

## Model - 3 Gearbox 15 ft. / Flex Wing Mowers

<b>Production Date</b>	<b>Serial Number</b>
<b>Start.....to.... End</b>	<b>Start s/n.....to..... End s/n</b>
<b>530</b> ..... May 1968..... Nov. 1973*	TK530-07195..... TK530-21446*
<b>CP180</b> ..... Dec. 1973..... Mar. 1976*	CP180-31188..... CP180-34724*
<b>X-3</b> ..... Apr. 1975..... Apr. 1978*	X-3-33388..... X-3-36782*
<b>TK15</b> ..... May 1978..... Sep. 1982*	TK15-36783..... TK15-39979*
<b>TK15HD</b> ..... Oct. 1982..... May 1987*	TK15HD-39980..... TK15HD-46051*
<b>A315</b> ..... Mar. 1990..... Sep. 1990*	A315-01001..... A315-10080*

\* \_ End of Production for this Model

## Model - 4 Gearbox 15 ft. Flex Wing Mowers

<b>Production Date</b>	<b>Serial Number</b>
<b>Start.....to.... End</b>	<b>Start s/n.....to..... End s/n</b>
<b>TK15-IV</b> ..... Mar. 1985..... May. 1987*	TK15-IV-42840..... TK15-IV-46051*
<b>AG15-IV</b> ..... Jun. 1987..... Mar. 2002*	AG15-IV-01001..... AG15-IV-04643*
<b>A415</b> ..... Jun. 1990..... Dec. 2002*	A415-01001..... A415-14000*
<b>ST15</b> ..... Jan 2002..... Current	ST15-C31200557203..... ST15-Current

\* \_ End of Production for this Model

## Archive Manual Part Numbers

<b>TK530</b> ..... 02980262	<b>TK15-IV</b> .....00761652
<b>CP180</b> ..... 02980263	<b>AG15-IV</b> ..... 00761652
<b>X-3</b> ..... 02980264	<b>A315</b> .....02980317
<b>TK15</b> ..... 02980265	<b>A415</b> .....02980316
<b>TK 15HD</b> .....02980265	<b>ST15</b> .....02980337

# INDEX - ST15 & ST10

ITEM	PAGE NO.
<b>AXLE ASY.</b>	
<b>Center Axle:</b>	
ST15-C31200557203 (Jan. 2002) to ST15-Current.....	26
<b>Wing Axle</b>	
ST15-C31200557203 (Jan. 2002) to ST15-Current.....	18, 19
<b>BLADE CARRIERS &amp; BLADES:</b>	
ST15-C31200557203 (Jan. 2002) to ST15-Current.....	48, 49, 50
<b>CHAIN GUARDS:</b>	
<b>Front:</b>	
ST15-C31200557203 (Jan. 2002) to ST15-Current.....	64 thru 69
<b>Rear:</b>	
ST15-C31200557203 (Jan. 2002) to ST15-Current.....	64 thru 69
<b>COUNTER WEIGHT: (10 foot Model)</b>	
ST15-C31300557203 (Jan. 2002) to ST15-Current.....	20
<b>CONTROL / LEVEL LIFT ROD:</b>	
ST15-C31200557203 (Jan. 2002) to ST15-Current.....	27
<b>DECK COMPONENT:</b>	
<b>Center Section:</b>	
ST15-C31200557203 (Jan. 2002) to ST15-C31200789311 (Oct. 2003)....	14, 15
ST15-C31200790311 (Nov. 2003) to ST15-Current.....	16, 17
<b>Wing Section:</b>	
ST15-C31200557203 (Jan. 2002) to ST15-Current.....	18, 19
<b>Skirt Assembly ST10:</b>	
ST15-C31300557203 (Jan. 2002) to ST15-Current.....	20, 21
<b>DRIVELINE ASY:</b>	
<b>PTO, Cat 5 C/V:</b>	
ST15-C31200557203 (Jan. 2002) to ST15-Current.....	32, 33
<b>INTERMEDIATE:</b>	
ST15-C31200557203 (Jan. 2002) to ST15-Current.....	35
<b>WING:</b>	
ST15-C31200557203 (Jan. 2002) to ST15-Currentt.....	34
<b>SLIP CLUTCH:</b>	
<b>Intermediate Driveline &amp; Wing Driveleine:</b>	
ST15-C31200557203 (Jan. 2002) to ST15-Current.....	36, 37
<b>GEARBOX ASY:</b>	
<b>Divider:</b>	
ST15-C31200557203 (Jan. 2002) to ST15-Current.....	38, 39
<b>Center:</b>	
ST15-C31200557203 (Jan. 2002) to ST15-Current.....	40, 41
<b>Right &amp; Right Wing:</b>	
ST15-C31200557203 (Jan. 2002) to ST15-Current.....	42 thru 45

# INDEX - ST15 & ST10

ITEM	PAGE NO.
<b>GEARBOX SHIELDS</b>	
ST15-C31200557203 (Jan. 2002) to ST15-Current.....	46, 47
<b>HITCH ASY (OPTIONAL PRECISION HITCH)</b>	
ST15-C31200557203 (Jan. 2002) to ST15-Current.....	24
<b>HYDRAULICS</b>	
<b>Schematic - Axle Lift Cylinders</b>	
ST15-C31200557203 (Jan. 2002) to ST15-C31200789311 (Oct. 2003).....	52, 53
ST15-C31200790311 (Nov. 2003) to ST15-Current.....	54, 55
<b>Schematic - Wing Lift &amp; Fold Cylinders</b>	
ST15-C31200557203 (Jan. 2002) to ST15-C31200789311 (Oct. 2003).....	58
ST15-C31200790311 (Nov. 2003) to ST15-Current.....	59
<b>Schematic - Control Valve:</b>	
ST15-C31200557203 (Jan. 2002) to ST15-Current.....	62
<b>Wing Lift Cyl:</b>	
ST15-C31200557203 (Jan. 2002) to ST15-C31200789311 (Oct. 2003).....	60
ST15-C31200790311 (Nov. 2003) to ST15-Current.....	61
<b>Axle Lift Cyl:</b>	
ST15-C31200557203 (Jan. 2002) to ST15-C31200789311 (Oct. 2003).....	56
ST15-C31200790311 (Nov. 2003) to ST15-Current.....	57
<b>Attachments:</b>	
<b>Axle Lift:</b>	
ST15-C31200557203 (Jan. 2002) to ST15-Current.....	18, 63
<b>Wing Lift:</b>	
ST15-C31200557203 (Jan. 2002) to ST15-Current.....	18, 63
<b>Valve Mnt:</b>	
ST15-C31200557203 (Jan. 2002) to ST15-Current.....	62
<b>INDEX / INTRODUCTION</b>	
Index .....	3 thru 5
Introduction.....	6 & 13
<b>PARKING JACK</b>	
ST15-C31200557203 (Jan. 2002) to ST15-Current.....	25
<b>SAFETY CHAIN</b>	
Safety Chain.....	70
<b>SAFETY SECTION</b>	
Safety Section.....	7 thru 12
<b>SKID SHOES</b>	
ST15-C31200557203 (Jan. 2002) to ST15-Current.....	16 thru 20
<b>TONGUE:</b>	
<b>Tongue:</b>	
ST15-C31200557203 (Jan. 2002) to ST15-Current.....	22, 23
<b>Precision Hitch: (Optional)</b>	
ST15-C31200557203 (Jan. 2002) to ST15-Current.....	24

# INDEX - ST15 & ST10

ITEM	PAGE NO.
<b>TIRE, WHEEL &amp; HUBS</b>	
ST15-C31200557203 (Jan. 2002) to ST15-Current.....	28 thru 31
<b>TRANSPORT LIGHT ASY:</b>	
ST15-C31200557203 (Jan. 2002) to ST15-Current.....	71
<b>WINCH &amp; STAND</b>	
ST15-C31200557203 (Jan. 2002) to ST15-Current.....	51
<b>WHEEL HUB</b>	
ST15-C31200557203 (Jan. 2002) to ST15-Current.....	28 thru 31

## Serial Number Identification Codes

### ST15 (C312) & ST10 (C313) 12 Digit Serial Number Break Down

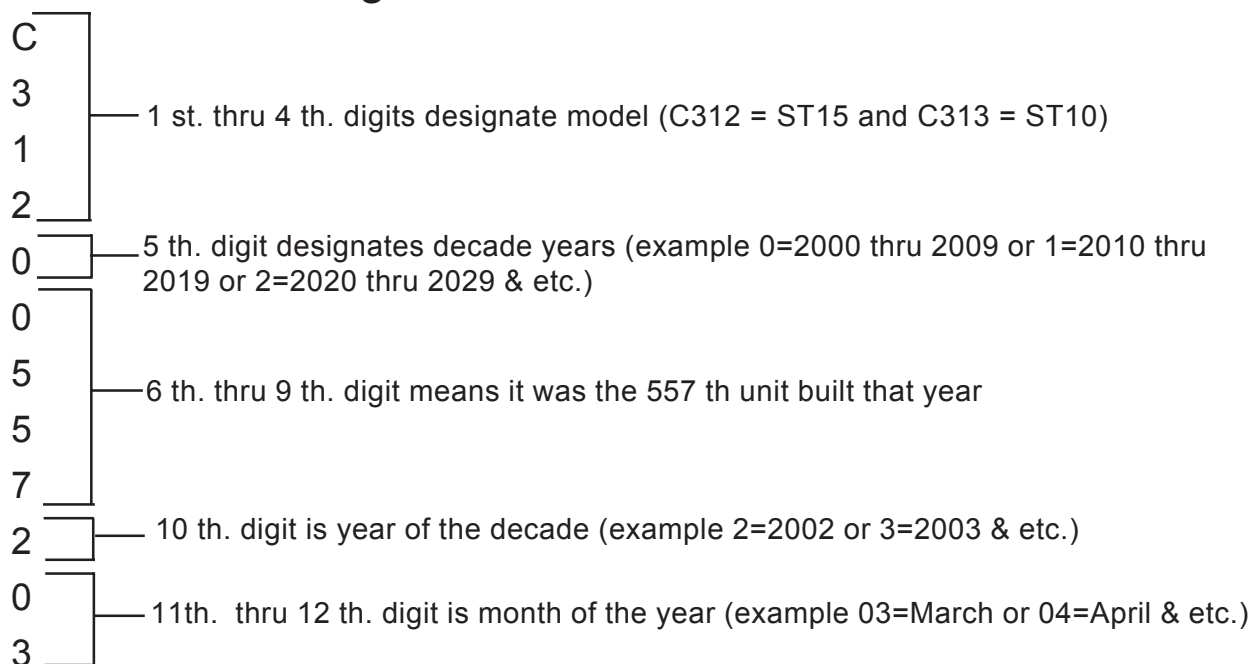

Summary: This serial number means, **C312** = ST15, **0** = 1 st. decade of century, **0557** = Five hundred and fifty seventh unit built this year, **2** = the year of the decade (2002), **03** = the month of the year (March)

# ST15 & ST10 ARCHIVE BOOK INTRODUCTION

The ST15 / ST10 Archive Book is a complete listing of Parts from the first Unit to the Present. The Production Dates, Serial Numbers, Special Notes and Descriptions are furnished to help find Replacement Parts. Dimension (if listed) are for Identification of Parts and MAY NOT be to Manufacturing Specification, Your measurements may vary some from dimensions listed. Some Parts may be changed and be different than parts listed. Some Modification may be required when replacing older parts. Match S/N's listed in this Book with the S/N's listed at the top of each Parts Page. See Index page for serial number code break down. The ST15 S/N will start with prefix C312 and ST10 prefix is C313, the first 4 digits of the 12 digit S/N designates the model.

## PAGE EXAMPLE

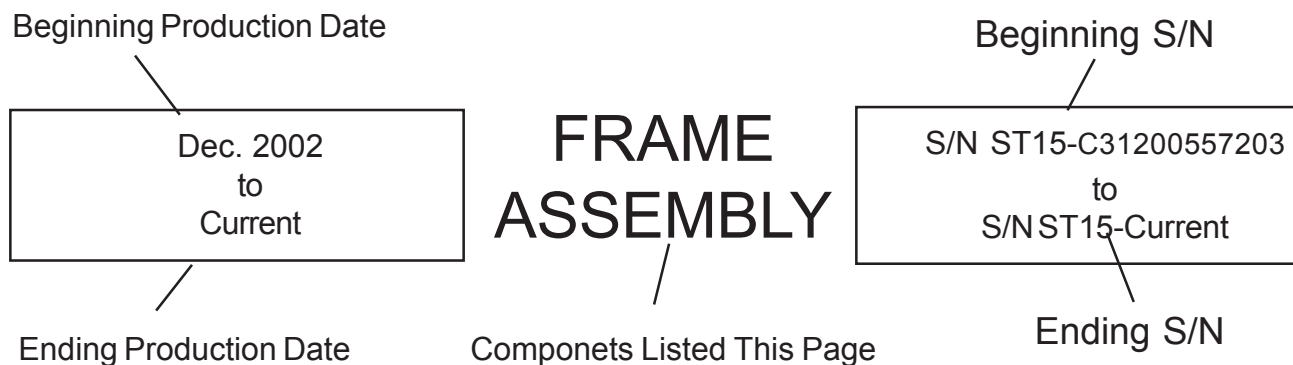

For ordering parts the following instructions are offered to help eliminate delay

1. The purchase order must include the Name, Address (Ship to Street Address) of the Person / Organization ordering the parts. Who / How Parts should be Billed. Name and Phone Number of a Contact Person at your end.
2. The Purchase Order must list clearly the correct Part Number of Part. Quantity of each Part wanted, Complete and correct Description of each Part. All Parts will be shipped as requested depending on availability and/or reasonability of request carrier / method.
3. Alamo Industrial reserves the right to substitute parts where applicable and change prices Without prior notice. Alamo Industrial also reserves the right to Ship Parts the most Reasonable way as determined by Alamo Industrial.
4. Some Parts are unlisted items, which are special production items not normally stocked or built for a limited / special use, These parts may be subject to special handling or cannot be priced till ordered. Always Request a quotation for such Parts before sending a purchase order.

# **SAFETY SECTION**

# SAFETY

Read these assembly instructions through completely and understand them before proceeding with the assembly of the equipment.

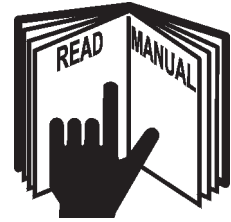

A safe and careful operator is the best operator. Safety is of primary importance to the manufacturer and should be to the owner/operator. Most accidents can be avoided by being aware of your equipment, your surroundings, and observing certain precautions. The first section of this manual includes a list of Safety Messages that, if followed, will help protect the operator and bystanders from injury or death. Read and understand these Safety Messages before assembling, operating or servicing this Implement. This equipment should only be operated by those persons who have read the Manual, who are responsible and trained, and who know how to do so safely and responsibly.

The Safety Alert Symbol combined with a Signal Word, as seen below, is used throughout this manual and on decals which are attached to the equipment. The Safety Alert Symbol means: **“ATTENTION! BECOME ALERT! YOUR SAFETY IS INVOLVED!”** The Symbol and Signal Word are intended to warn the owner/operator of impending hazards and the degree of possible injury faced when operating this equipment..

**Practice all usual and customary safe working precautions and above all---remember safety is up to YOU. Only YOU can prevent serious injury or death from unsafe practices.**

## CAUTION!

The lowest level of Safety Message; warns of possible injury. Decals located on the Equipment with this Signal Word are Black and Yellow.



## WARNING!

Serious injury or possible death! Decals are Black and Orange.



## DANGER!

Imminent death/critical injury. Decals are Red and White. (SG-1)





# SAFETY

**PELIGRO!**



Si no lee Ingles, pida ayuda a alguien que si lo lea para que le traduzca las medidas de seguridad. (SG-3)



**!LEA EL INSTRUCTIVO!**

**READ, UNDERSTAND, and FOLLOW the following Safety Messages. Serious injury or death may occur unless care is taken to follow the warnings and instructions stated in the Safety Messages. Always use good common sense to avoid hazards.**

(SG-2)



**PELIGRO!**



Si no lee Ingles, pida ayuda a alguien que si lo lea para que le traduzca las medidas de seguridad. (SG-3)

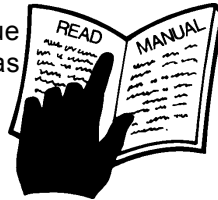

**! LEA EL INSTRUCTIVO!**

**WARNING!**



Perform service, repairs and lubrication according to the maintenance section. Ensure the unit is properly lubricated as specified in the lubrication schedule and all bolts and nuts are properly torqued. Failure to properly service, repair and maintain this Implement in good operating condition could cause component failure and possible serious injury or even death. (SG-35)

**WARNING!**



Operate this Equipment only with a Tractor equipped with an approved roll-over-protective system (ROPS). Always wear seat belts. Serious injury or even death could result from falling off the tractor--particularly during a turnover when the operator could be pinned under the ROPS. (SG-7)



**DANGER!**



Never work under the Implement, the framework, or any lifted component unless the Implement is securely supported or blocked up to prevent sudden or inadvertent falling which could cause serious injury or even death. (SG-14)



**WARNING!**



Use caution and wear protective gloves when handling sharp objects such as blades, knives, and other cutting edges. Be alert to worn component surfaces which have sharp edges. Sharp surfaces can inflict severe laceration injuries if proper hand protection is not worn. (SG-37)

# SAFETY

## WARNING!



Many of the parts are heavy and require lifting assistance. Do not try to lift the heavy parts by yourself. Get help from another employee or from an overhead crane.

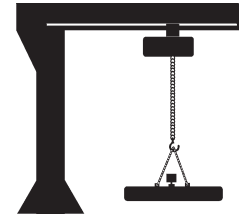

## WARNING!



The operator and all support personnel should wear hard hats, safety shoes, safety glasses, and proper hearing protection at all times for protection from injury including injury from items thrown by the equipment. (SG-16)

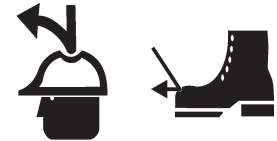

## WARNING!



Always wear safety shoes with steel toes when working on this equipment. It is recommended that the safety shoes have metatarsal guards.

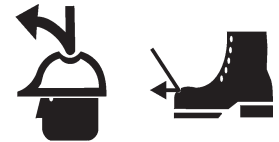

## WARNING!



When welding use Welding hood with the appropriate OSHA required protective lens, welding apron, and welding gloves.



## DANGER!



Always disconnect the wire leads from the mower valve solenoid before performing service on the Tractor or Mower. Use caution when working on the Tractor or Mower. Tractor engine must be stopped before working on Mower or Tractor. The Mower Blades could inadvertently be turned on without warning and cause immediate dismemberment, injury or death. (SBM-12)

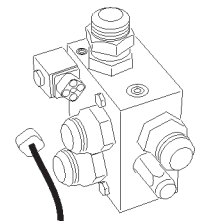

## DANGER!



Never run the tractor engine in a closed building or without adequate ventilation. The exhaust fumes can be hazardous to your health.

(SG-23)

# SAFETY

**DANGER!**



Before starting the mower make sure the area is clear and the floor has been swept. The mower blade can throw objects several hundred feet. Thrown objects could damage property or cause severe bodily injuries even death.

**WARNING!**



Make certain that the "Slow Moving Vehicle" (SMV) sign is installed in such a way as to be clearly visible and legible. When transporting the Equipment use the Tractor flashing warning lights and follow all local traffic regulations. (SG-6)

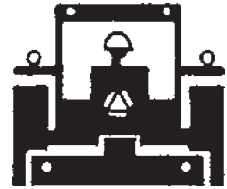

**DANGER!**



Start tractor only when properly seated in the Tractor seat. Starting a tractor in gear can result in injury or death. Read the Tractor operators manual for proper starting instructions. (SG-13)



**DANGER!**



Do not operate this Equipment with hydraulic oil leaking. Oil is expensive and its presence could present a hazard. Do not check for leaks with your hand! Use a piece of heavy paper or cardboard. High-pressure oil streams from breaks in the line could penetrate the skin and cause tissue damage including gangrene. If oil does penetrate the skin, have the injury treated immediately by a physician knowledgeable and skilled in this procedure. (SG-15)



**WARNING!**



Always read carefully and comply fully with the manufacturers instructions when handling oil, solvents, cleansers, and any other chemical agent. (SG-22)



**DANGER!**



All Safety Shields, Guards and Safety devices including (but not limited to) - the Deflectors, Chain Guards, Steel Guards, Gearbox Shields, PTO integral shields, and Retractable Door Shields should be used and maintained in good working condition. All safety devices should be inspected carefully at least daily for missing or broken components. Missing, broken, or worn items must be replaced at once to reduce the possibility of injury or death from thrown objects, entanglement, or blade contact. (SGM-3)

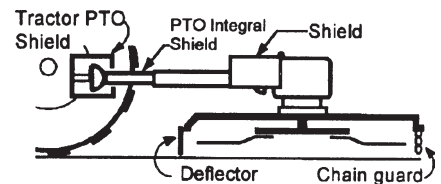

# SAFETY

## DANGER!



**NEVER use drugs or alcohol** immediately before or while operating the Tractor and Implement. Drugs and alcohol will affect an operator's alertness and coordination and therefore affect the operator's ability to operate the equipment safely. Before operating the Tractor or Implement, an operator on prescription or over-the-counter medication must consult a medical professional regarding any side effects of the medication that would hinder their ability to operate the Equipment safely. **NEVER** knowingly allow anyone to operate this equipment when their alertness or coordination is impaired. Serious injury or death to the operator or others could result if the operator is under the influence of drugs or alcohol. (SG-27)



## DANGER!



Operate the Tractor and/or Implement controls only while properly seated in the Tractor seat with the seat belt securely fastened around you. Inadvertent movement of the Tractor or Implement may cause serious injury or death. (SG-29)

## WARNING!



**Engine Exhaust, some of its constituents, and certain vehicle components contain or emit chemicals known to the state of California to cause cancer and birth defects or other reproductive harm.** (SG-30)

## WARNING!



**Battery posts, terminals and related accessories contain lead and lead compounds, chemicals known to the state of California to cause cancer and birth defects or other reproductive harm. Wash Hands after handling.** (SG-31)

## WARNING!



Use extreme caution when getting onto the Implement to perform repairs, maintenance and when removing accumulated material. Only stand on solid flat surfaces to ensure good footing. Use a ladder or raised stand to access high spots which cannot be reached from ground level. Slipping and falling can cause serious injury or death. (SG-33)

## WARNING!



Avoid contact with hot surfaces including hydraulic oil tanks, pumps, motors, valves and hose connections. Relieve hydraulic pressure before performing maintenance or repairs. Use gloves and eye protection when servicing hot components. Contact with a hot surface or fluid can cause serious injury from burns or scalding. (SG-34)

## WARNING!



Avoid contact with hot surfaces of the engine or muffler. Use gloves and eye protection when servicing hot components. Contact with a hot surface or fluid can cause serious injury from burns or scalding. (SG-38)

# ST15 / ST10

## Flex Wing Rotary

### ARCHIVE BOOK

#### **ST15 Archive Book**

This is a complete listing of Parts from the first Unit to the Present (or end of model production). The Production Dates, Serial Numbers, Special Notes and Descriptions are furnished to help find Replacement Parts. Dimension (if listed) are for Identification of Parts and MAY NOT be to Manufacturing Specification, Your measurements may vary some from dimensions listed. Some Parts may be changed and be different than parts listed. Some Modification may be required when replacing older parts. Match S/N' and Ship Dates if available.

#### **ID The ST15 (Jan 2002 to Current)**

The ST10 & ST15 was built from Jan. 2002 (s/n ST15-C31200557203) to Current (s/nST-Current) .

#### **Serial Numbers:**

See The Index Pages for an explanation on of how to identify your unit by the 12 digit serial number code, The Serial number code shows manufacturing production date of your unit.

#### **Gearboxes:**

The best way to ID the ST10 & ST15 (Stingray Model) is by the Gearboxes, This is a 4 Gearbox Model (Divider and Center Blade Gearbox two separate gearboxes). The Divider gearbox has a 1-3/8" X 21 Spline Output Shafts. The Blade Gearbox (Center & Wings) has a long section of the Housing that protrudes below where it bolts to the deck. The Blade Gearbox has a Dip-Stick type top Plug. The Blade Carrier Retaining Nut used a Cone Shaped Washer which no other model has to this time.

#### **Blade Carriers:**

The Blade Carriers are a Round Shaped Pan Weldment. The Blade Bolts are a Shouldered Blade Bolt, and a bushing is used with the Blade Bolt. This was not the only 4 gearbox model that had a Shoulder Blade Bolt but is the only model to use a bushing with the Shoulder Bolt.

#### **Driveline Options:**

There were no Driveline size options, There was a Cat IV (4) Wing Drivelines and a Cat V (5) PTO Driveline used on this model. Some parts will not interchange between drivelines. See Part numbers for interchangeable parts.

#### **Axles:**

The axles are Independent from center to wings. The type Hydraulic Axle lift is a Phasing (Slave) Cylinder system, the Hydraulic lift of the mower is done by using 3 hydraulic Cylinders mounted one in the center and one on each wing. The Cylinders are connected together into one Hydraulic flow in series.

Jan. 2002  
to  
Oct. 2003

# DECK COMPONENTS Center Section ST15 / ST10

ST15-C31200557203  
to  
ST15-C31200789311

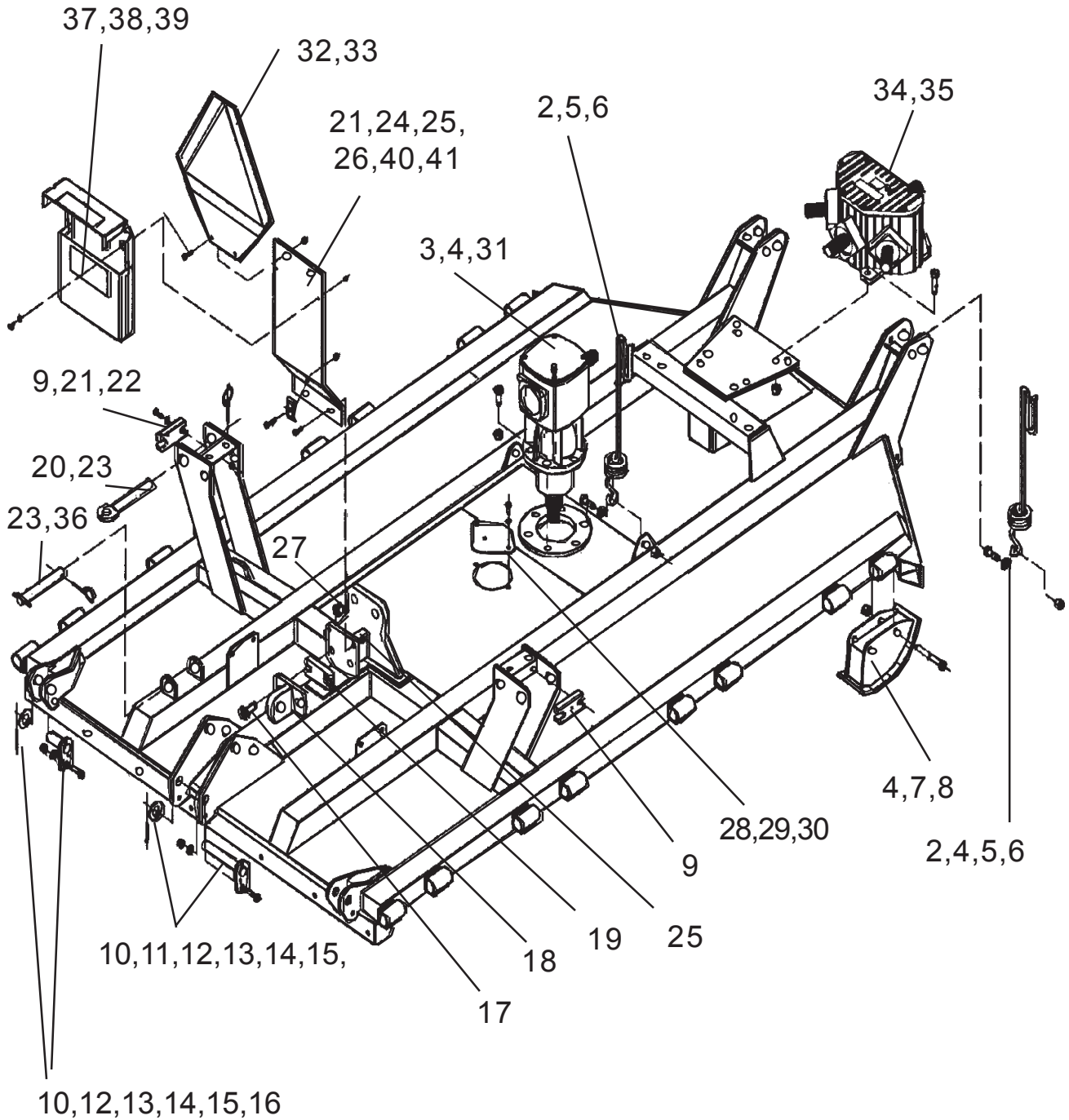

Jan. 2002  
to  
Oct. 2003

## DECK COMPONENTS Center Section ST15 / ST10

ST15-C31200557203  
to  
ST15-C31200789311

Item	Part No.	Qty.	Description
1	02978500	1	Center Section Asy
2	02978501	2	Hose Organizer
3	00755082	6	Bolt
4	000944	16	Lock Nut
5	00008300	2	Bolt
6	15B1200	2	Flat Washer
7	02978502	2	Skid Mount Asy
8	02975147	4	Bolt
9	02978503	2	Wing Lift Spacer Plate
10	02891800	2	Bolt
11	02978504	1	Retainer Pin, Long Center Pin
12	15B800	3	Flat Washer
13	00001800	3	Lock Nut
14	15B1600	3	Flat Washer
15	01408S	3	Roll Pin
16	02978505	2	Retainer Pin, Outer Pins
17	02959332	2	Bolt
18	02978506	1	Cylinder Lug Adj. Asy.
19	02978507	1	Spacer Plate
	02978508	1	Spacer Plate
20	02978509	2	Wing Lock Pin,
21	02957042	4	Bolt
22	15B600	4	Flat Washer
23	02978510	3	Lynch Pin
24	02978511	1	Slow Moving Vehicle Sign Stand
25	00015800	8	Lock Nut
26	00753642	2	Bolt
27	00037200	2	Lock Nut
28	02978512	1	Bolt Access Cover Plate
29	00012101	2	Lock Washer
30	10180500	2	Bolt
31	02978513	1	Gearbox Asy, CW, 540 RPM
	02978971	1	Gearbox Asy, CW, 1000 RPM
32	10180500	2	Bolt
33	02978915	1	SMV Sign
34	02978514	1	Gearbox Asy, Divider, 540 RPM
	02978968	1	Gearbox Asy, Divider, 1000 RPM
35	00753753	4	Bolt
36	02978515	1	Transport Lock Pin
37	02978516	1	Operator / Parts Manual Box
38	00024100	2	Flat Washer
39	10058000	2	Bolt
40	02962363	2	Lock Nut
41	02978638	1	Hose Clamp

Nov. 2003  
to  
Current

# DECK COMPONENTS Center Section ST15 / ST10

ST15-C31200790311  
to  
ST15-Current

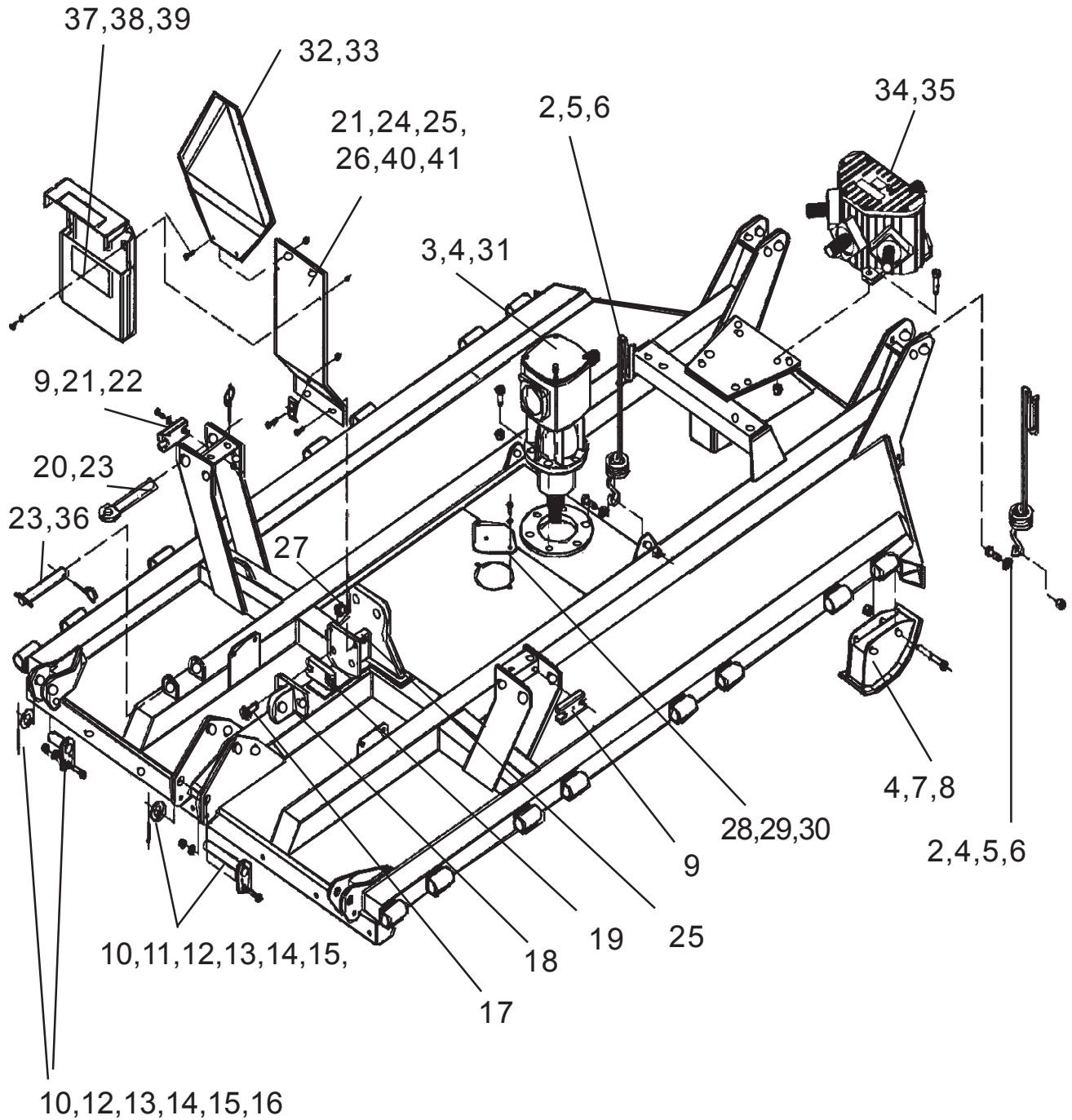



Nov. 2003  
to  
Current

## DECK COMPONENTS

### Center Section

### ST15 / ST10

ST15-C31200790311  
to  
ST15-Current

Item	Part No.	Qty.	Description
1	02978500	1	Center Section Asy
2	02978501	2	Hose Organizer
3	00755082	6	Bolt
4	000944	16	Lock Nut
5	00008300	2	Bolt
6	15B1200	2	Flat Washer
7	02978502	2	Skid Mount Asy
8	02975147	4	Bolt
9	02978503	2	Wing Lift Spacer Plate
10	02891800	2	Bolt
11	02978504	1	Retainer Pin, Long Center Pin
12	15B800	3	Flat Washer
13	00001800	3	Lock Nut
14	15B1600	3	Flat Washer
15	01408S	3	Roll Pin
16	02978505	2	Retainer Pin, Outer Pins
17	03200369	2	Bolt, (Light Truck Tire)
	02959332	2	Bolt, (Laminated & Aircraft Tire)
18	02978506	1	Cylinder Lug Adj. Asy.
19	02978507	1	Spacer Plate, (Light Truck Tire)
	02978508	1	Spacer Plate, (Laminated & Aircraft Tire)
20	02978509	2	Wing Lock Pin,
21	02957042	4	Bolt
22	15B600	4	Flat Washer
23	02978510	3	Lynch Pin
24	02980471	1	Slow Moving Vehicle Sign Stand
25	00015800	8	Lock Nut
26	00753642	2	Bolt
27	00037200	2	Lock Nut
28	02978512	1	Bolt Access Cover Plate
29	00012101	2	Lock Washer
30	10180500	2	Bolt
31	02978513	1	Gearbox Asy, CW, 540 RPM
	02978971	1	Gearbox Asy, CW, 1000 RPM
32	10180500	2	Bolt
33	03200347	1	SMV Sign
34	02978514	1	Gearbox Asy, Divider, 540 RPM
	02978968	1	Gearbox Asy, Divider, 1000 RPM
35	00753753	4	Bolt
36	02978515	1	Transport Lock Pin
37	02978516	1	Operator / Parts Manual Box
38	00024100	2	Flat Washer
39	10058000	2	Bolt
40	02962363	2	Lock Nut
41	02978638	1	Hose Clamp

Jan. 2002  
to  
Current

# DECK COMPONENTS

## Wing Section

### ST15 / ST10

ST15-C31200557203  
to  
ST15-Current

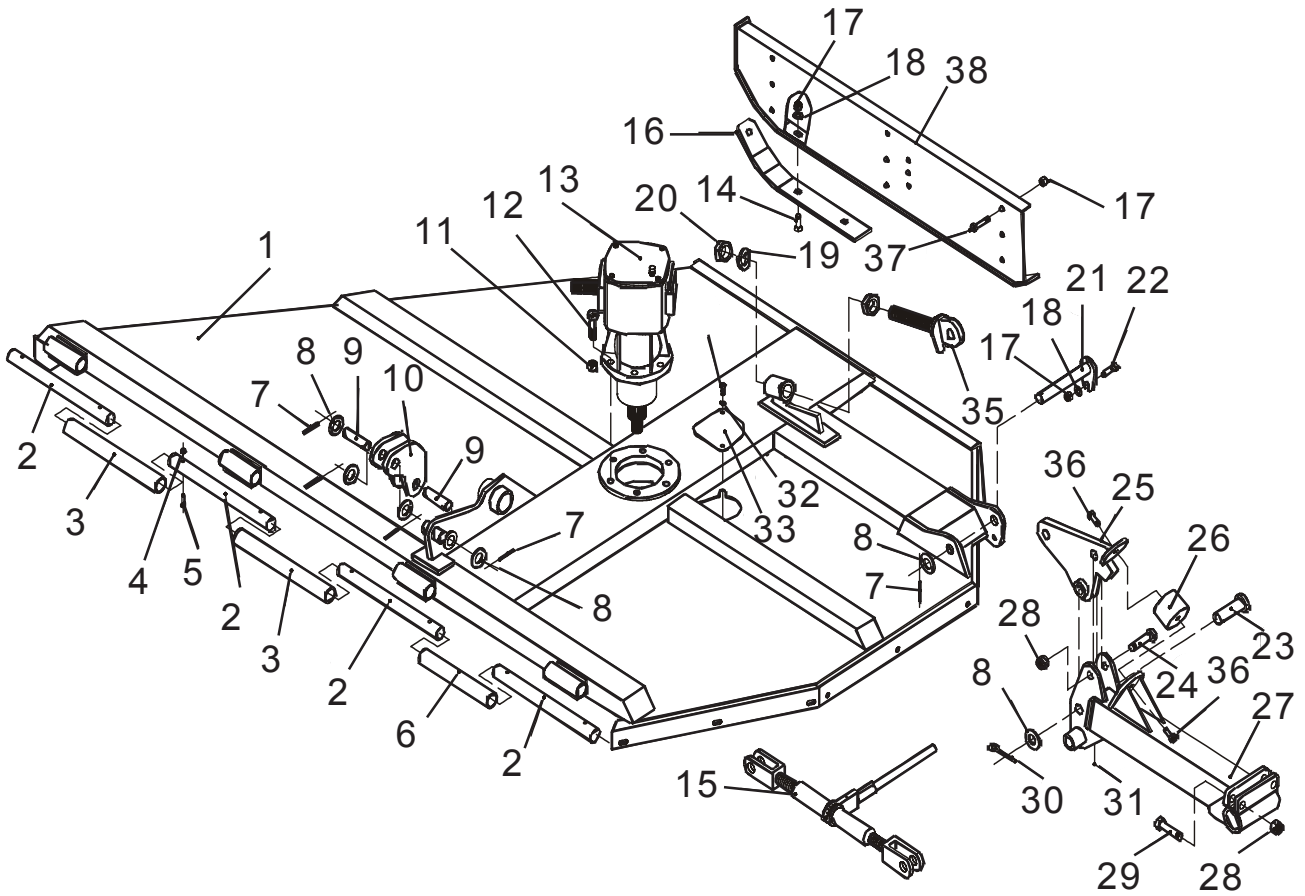

Jan. 2002  
to  
Current

## DECK COMPONENTS Wing Section ST15 / ST10

ST15-C31200557203  
to  
ST15-Current

Item	Part No. R-Wing	Part No. L-Wing	Qty.	Description
1	02978517 -----	----- 02978532	1 1	Wing Asy, R-Wing (Shown) Wing Asy, L-Wing (Not Shown)
2	02978518	02978518	4	Hinge Pin
3	02978519	02978519	2	Hinge Spacer Tube
4	00749017	00749017	8	Lock Nut
5	10121000	10121000	8	Bolt
6	02978520	02978520	1	Hinge Spacer Tube
7	01408S	01408S	5	Roll Pin
8	15B1600	15B1600	6	Flat washer
9	02978521	02978521	2	Pin
10	02978522	02978522	2	Floating lug
11	000944	000944	6	Lock Nut
12	00755082	00755082	6	Bolt
13	02978523 -----	----- 02978533	1 1	Gearbox, CCW R-Wing Gearbox, CW L-Wing
14	2A381312	2A381312	3	Plow Bolt
16	02978525	02978525	1	Skid Shoe, L or R Wing
17	00001800	00001800	10	Lock Nut
18	15B800	15B800	10	Flat Washer
19	02978795	02978795	1	Lock Washer
20	331212C	331212C	2	Half Nut
21	02978526	02978526	1	Retainer Pin
22	02892000	02892000	1	Bolt
23	02978527	02978527	1	Clevis Pin
24	02959332	02959332	1	Bolt
25	02978528	02978528	1	Wheel Suspension Plate, Standard
26	00751035	00751035	1	Rubber Sandwich
27	02978529	02978529	1	Wing Wheel Standard Asy.
28	00037200	00037200	5	Lock Nut
29	03200269	03200269	2	Bolt
30	00755153	00755153	1	Cotter Pin
31	001291	001291	1	Grease Nipple, Self tap
32	02978512	02978512	1	Bolt Access Cover Plate
33	00012101	00012101	2	Lock Washer
34	10180500	10180500	2	Bolt
35	02978530	02978530	1	Wing Adj. Assy.
36	00011800	00011800	2	Bolt
37	02776600	02776600	6	Bolt
38	02978531 -----	----- 02978534	1 1	Adjustable Side Mount, R-Wing Adjustable Side Mount, L-Wing

Note: Qty Shown above is for one Wing, double qty of parts for both wings w/ the exception of items 1, 13 & 38 which must be used on a specific wing.

Jan. 2002  
to  
Current

# SKIRT ASY ST10

ST15-C31200557203  
to  
ST15-Current

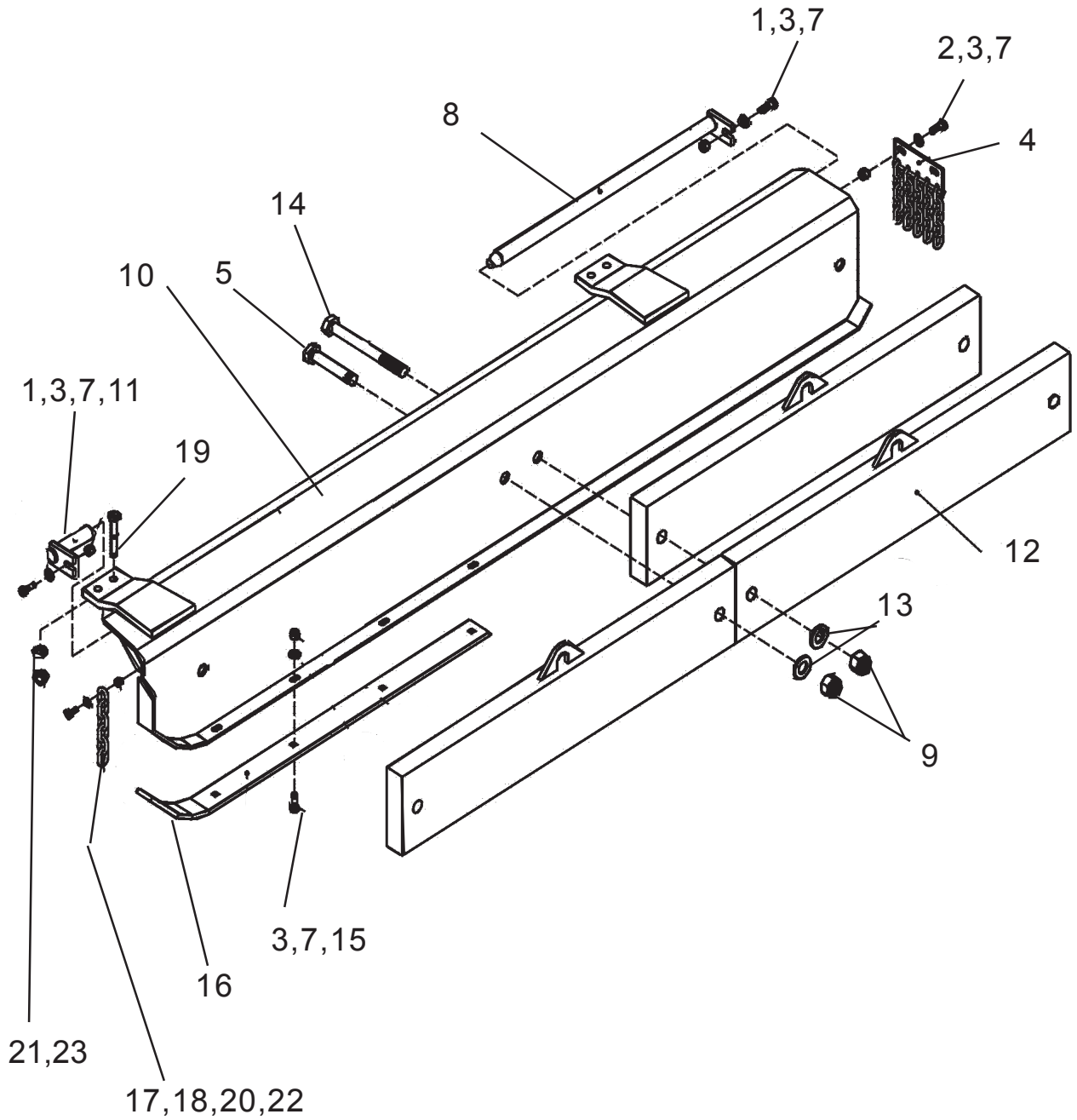

Jan. 2002  
to  
Current

## SKIRT ASY ST10

ST15-C31200557203  
to  
ST15-Current

Item	Part No.	Qty.	Description
1	02891800	2	Bolt
2	02892000	2	Bolt
3	15B800	9	Flat washer
4	02978551	1	Chain guard, double
5	250-145	2	Bolt
7	00001800	9	Lock nut
8	02978552	1	Hinge pin
9	02030300	4	Lock nut
10	02978553	1	Skirt Assy, 10' Unit Only
11	02978554	1	Hinge pin
12	02978555	2	Counter weight
13	15B1600	4	Flat washer
14	00755305	2	Bolt
15	2A381312	5	Plow bolt,
16	02978556	1	Skirt skid
17	00015800	3	Lock nut
18	02978557	3	Chain, 11 links
19	02975147	4	Bolt
20	15B600	3	Flat washer
21	15B1200	4	Flat washer
22	00752675	3	Bolt
23	000944	4	Lock nut

Jan. 2002  
to  
Current

# TONGUE ASY. ST15 / ST10

ST15-C31200557203  
to  
ST15-Current

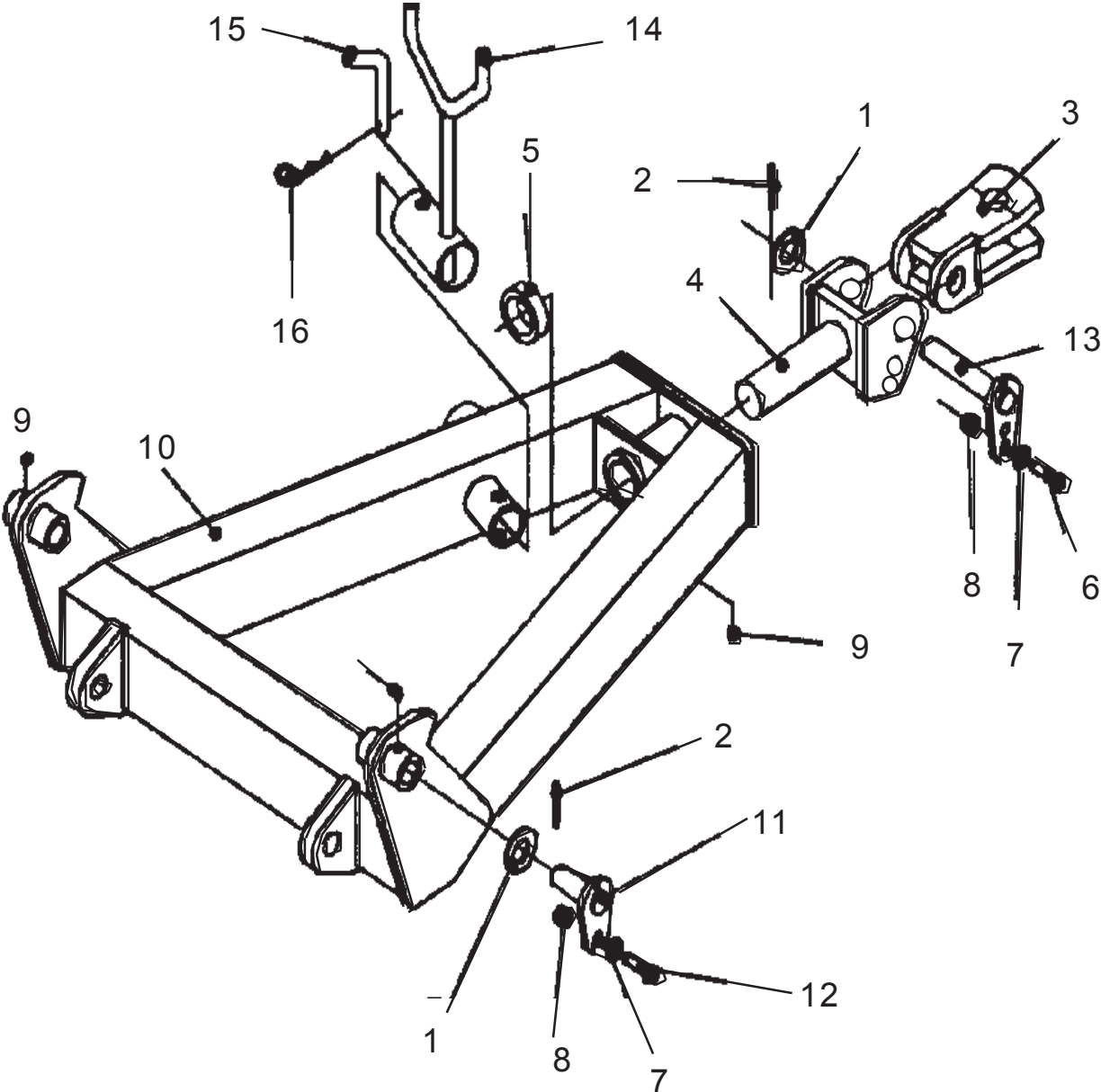

Jan. 2002  
to  
Current

## TONGUE ASY. ST15 / ST10

ST15-C31200557203  
to  
ST15-Current

Item	Part No.	Qty.	Description
1	15B1600	3	Flat Washer
2	01408S	3	Roll Pin
3	02978536	1	Hitch Clevis, Standard Clevis
4	02978537	1	Pivoting Hitch Asy.
5	02978538	1	Pivot Hitch Weld Sleeve
6	02891800	1	Bolt
7	15B800	3	Flat Washer
8	00001800	3	Lock Nut
9	001291	6	Grease Fitting
10	02978539	1	Hitch Frame Assy.
11	02978540	2	Retaining Pin
12	02892000	2	Bolt
13	02978547	1	Retaining Pin
14	02978548	1	PTO Storage Support
15	02978549	1	Bent Hitch Pin
16	02978550	1	Hitch Pin Clip

Note: Item # 3 is the standard Tongue Hitch Clevis , there is an Optional Hitch Clevis offered called Precision Hitch Kit # 02978611. See Parts break down for this optional hitch.

Jan. 2002  
to  
Current

# PRECISION HITCH OPTION ST15 / ST10

ST15-C31200557203  
to  
ST15-Current

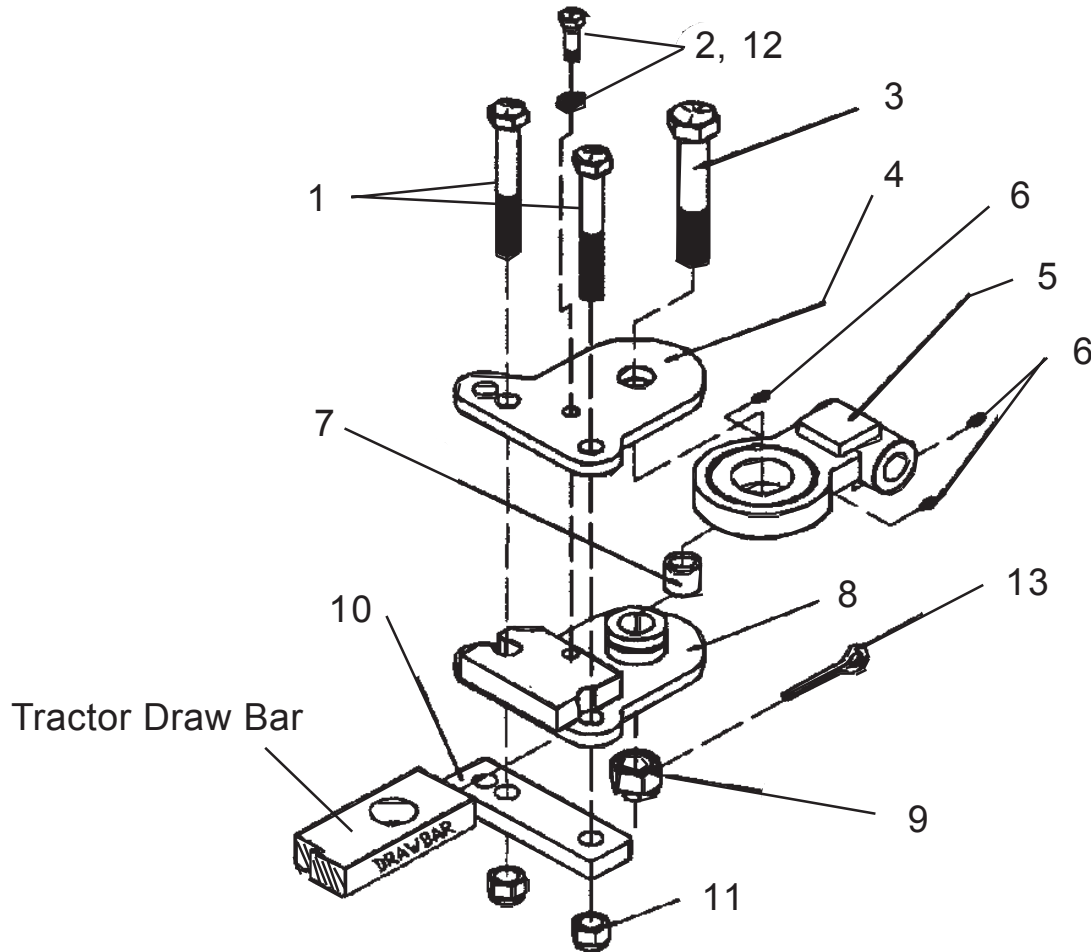

Item	Part No.	Qty.	Description
	02978611	--	Precision Hitch Kit (Optional)
1	00752405	2	Bolt
2	02892000	1	Bolt
3	02010800	1	Bolt
4	02978608	1	Drawbar Clevis Top
5	02978609	1	Hitch Tongue
6	00003500	3	Grease Nipple
7	02978610	1	Spacer
8	02978612	1	Drawbar Clevis Base
9	02978796	1	Lock Nut
10	02978613	1	Clamp Bar
11	00037200	2	Lock Nut
12	00001300	1	Lock Washer
13	00036900	1	Cotter Pin



Jan. 2002  
to  
Current

# PARKING JACK ST15 / ST10

ST15-C31200557203  
to  
ST15-Current

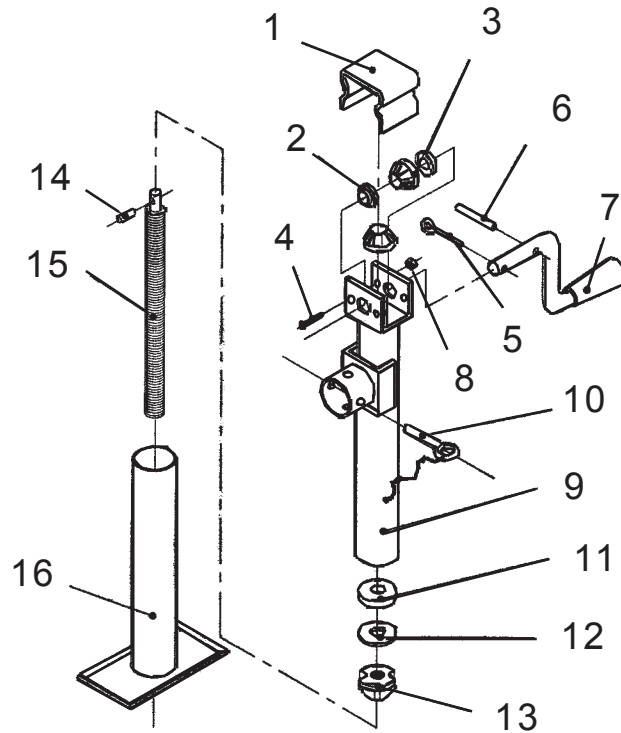

Item	Part No.	Qty	Description
	02979699	--	Parking Jack Asy.
1	02979700	1	Cover
2	02979701	2	Bushing
3	02979702	2	Gear
4	02979703	2	Carriage Bolt
5	40010000	2	Cotter Pin
6	02979704	1	Dowel
7	02979705	1	Handle
8	00024000	1	Nut
9	02979706	1	Body
10	02979707	1	Pin
11	02979708	1	Bearing
12	02979709	1	Washer
13	02979710	2	Nut
14	02979711	1	Dowel
15	02979712	1	Screw
16	02979713	1	Leg

Jan. 2002  
to  
Current

# AXLE - CENTER ST15 / ST10

ST15-C31200557203  
to  
ST15-Current

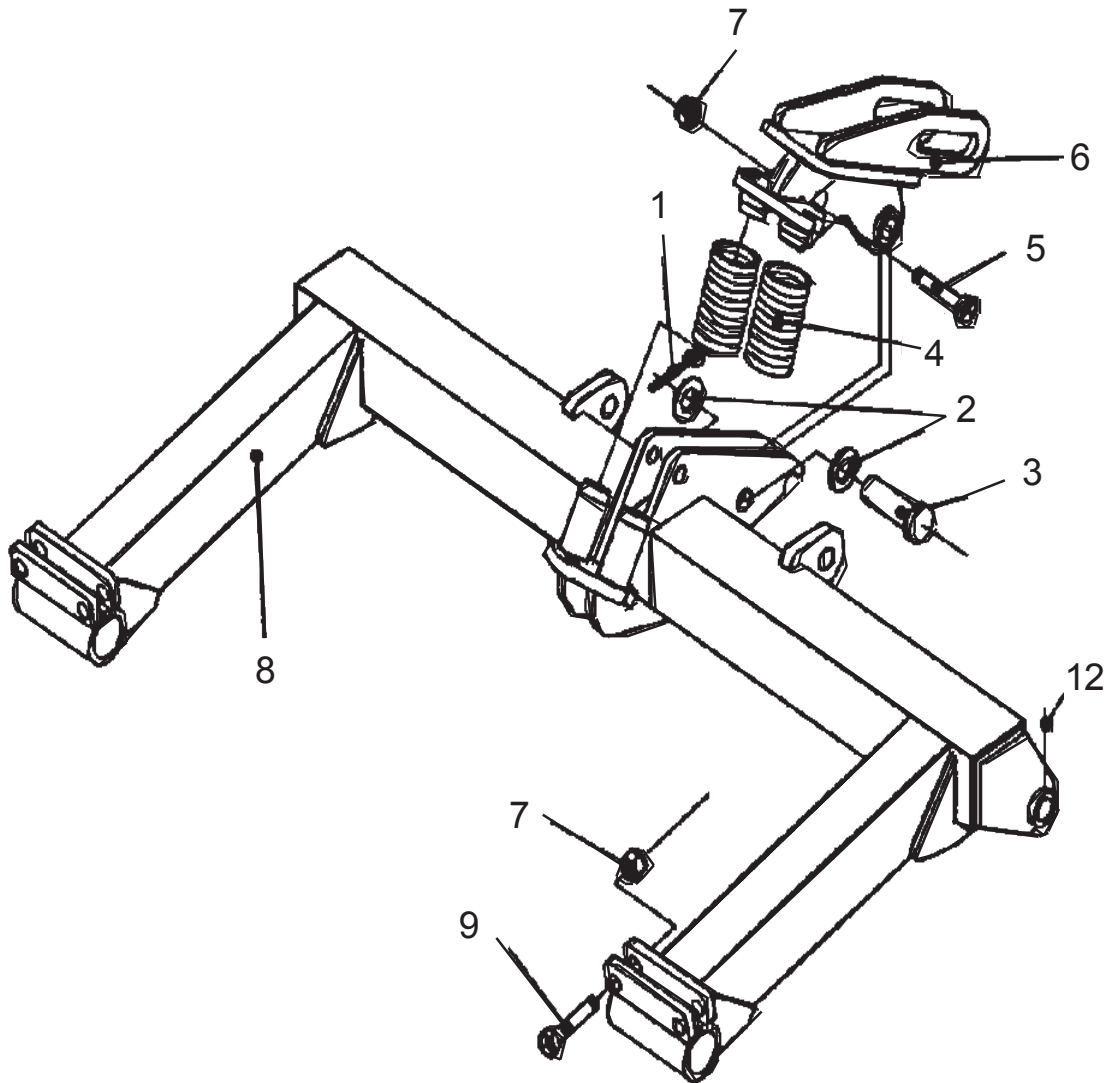

Item	Part No.	Qty.	Description
1	00755153	3	Cotter Pin
2	15B1600	2	Flat Washer
3	02978527	1	Clevis Pin
4	02978542	2	Compression Spring
5	02959332	1	Bolt
6	02978543	1	Suspension Top Plate
7	00037200	5	Lock Nut
8	02978546	1	Center Section Wheel Standard
9	03200269	4	Bolt

Jan. 2002  
to  
Current

## CONTRL ROD ST15 / ST10

ST15-C31200557203  
to  
ST15-Current

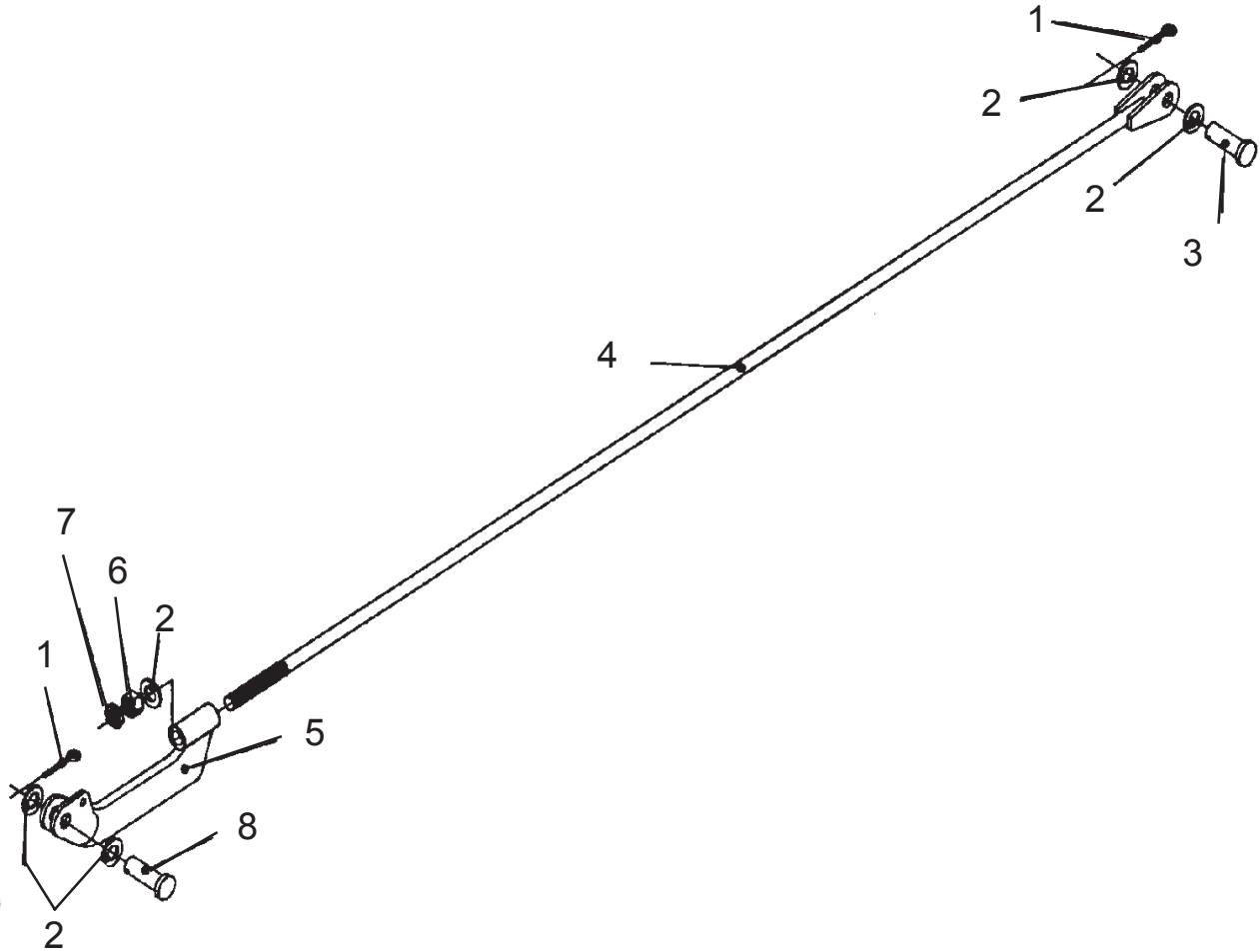

Item	Part No.	Qty	Description
1	00755153	3	Cotter Pin
2	15B1600	13	Flat Washer
3	02978535	2	Clevis Pin
4	02978541	2	Lift Rod
5	02978544	2	Leveling Rod Lug
6	00059500	2	Nut
7	23511000	2	Half Nut
8	02978545	2	Clevis Pin

Note: Qty listed is for two control rods, left & Right side.

Jan. 2002  
to  
Current

# TIRES & WHEELS ST15 / ST10

ST15-C31200557203  
to  
ST15-Current

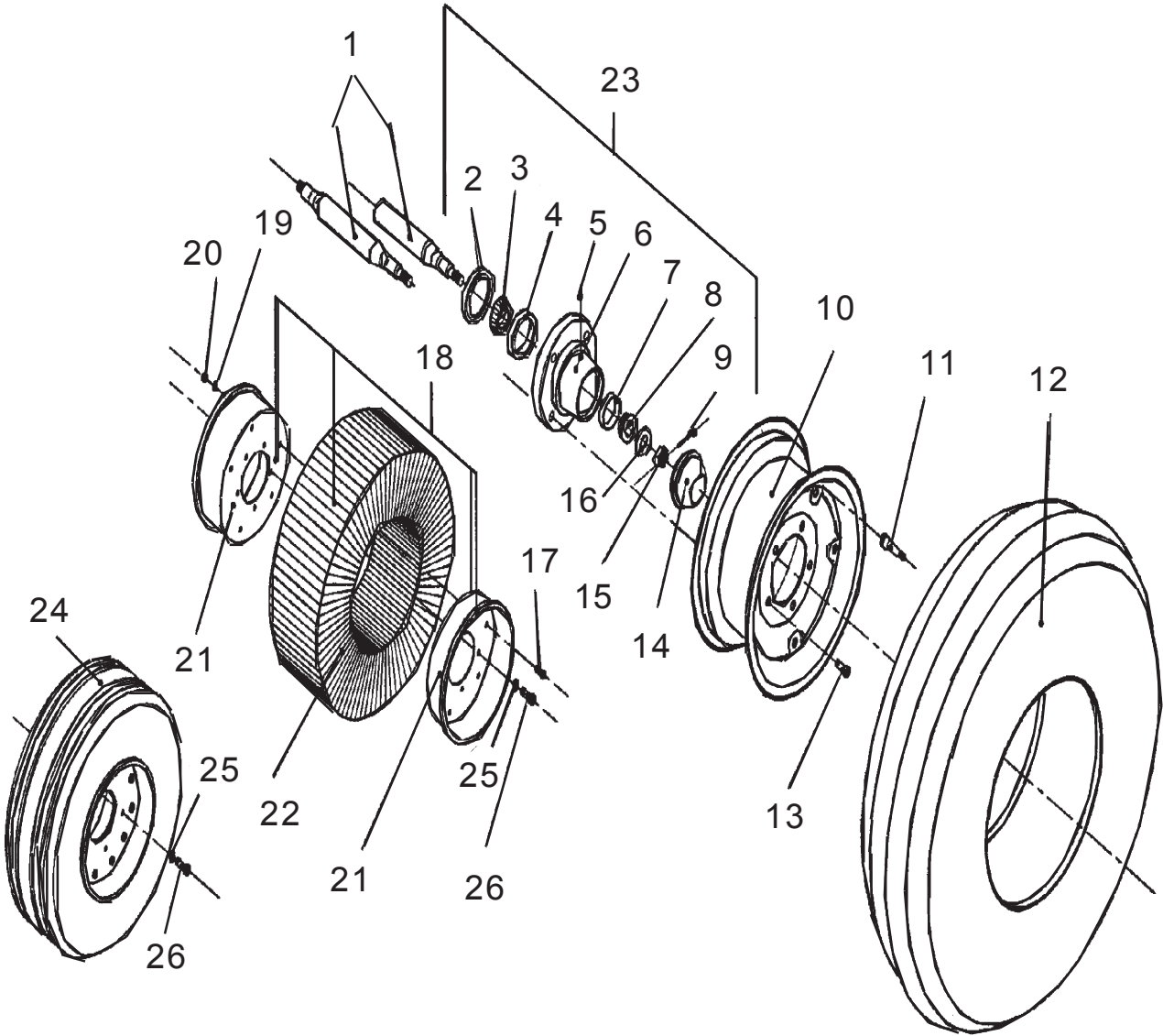

Jan. 2002  
to  
Current

## TIRES & WHEELS ST15 / ST10

ST15-C31200557203  
to  
ST15-Current

Item	Part No.	Qty.	Description
1	02978573	1	Spindle, w/ #9, 15, 16, Double End
1	02978574	1	Spindle, w/ #9, 15, 16, Single End
2	02978575	1	Seal
3	02978576	1	Bearing
4	02978577	1	Race
5	001291	1	Grease Fitting
6	02978578	1	Hub, w/ Bearing Cups
7	02978579	1	Race
8	02978580	1	Bearing
9	000163	1	Cotter Pin
10	02978930	1	Wheel 15"
11	02978931	1	Valve Stem
12	02978932	1	Tire
13	00749171	5	Wheel Bolt
14	02978581	1	Dust Cap
15	5E12160	1	Castle Nut
16	02978582	1	Machine Bushing
17	10180500	5	Bolt
18	02978797	1	Tire, Solid Laminated, Complete
19	00012101	5	Lockwasher
20	00013901	5	Nut
21	02978798	2	Wheel Half, 6 x 9, 5 Bolt
22	02978799	1	Tire, Solid Laminated, 6 x 9
23	02978583	1	Hub, Includes #2-8 & 14 1
23	02978584	1	Bearing Kit, Includes #2, 3, 4, 7, 8, 14, 16
24	02978800	1	Aircraft Tire 22 x 6.6 x 10 Complete
	02978801		Tube & Liner For #02978800
25	00001300	5	Lockwasher
26	00749171	5	Bolt

Jan. 2002  
to  
Current

# TIRES & WHEELS ST15 / ST10

ST15-C31200557203  
to  
ST15-Current

## WHEEL ATTACHMENT

### Laminated Tire and Wheels:

Attach the wheels to the hubs. If puncture-proof, Laminated Tires and Wheels are used, be sure the flat side of the nut is against the Wheel. Tighten wheel bolts to 85 ft/lbs. Note direction of travel and curvature of rubber segments in tire and install as shown below to give longest tire life.

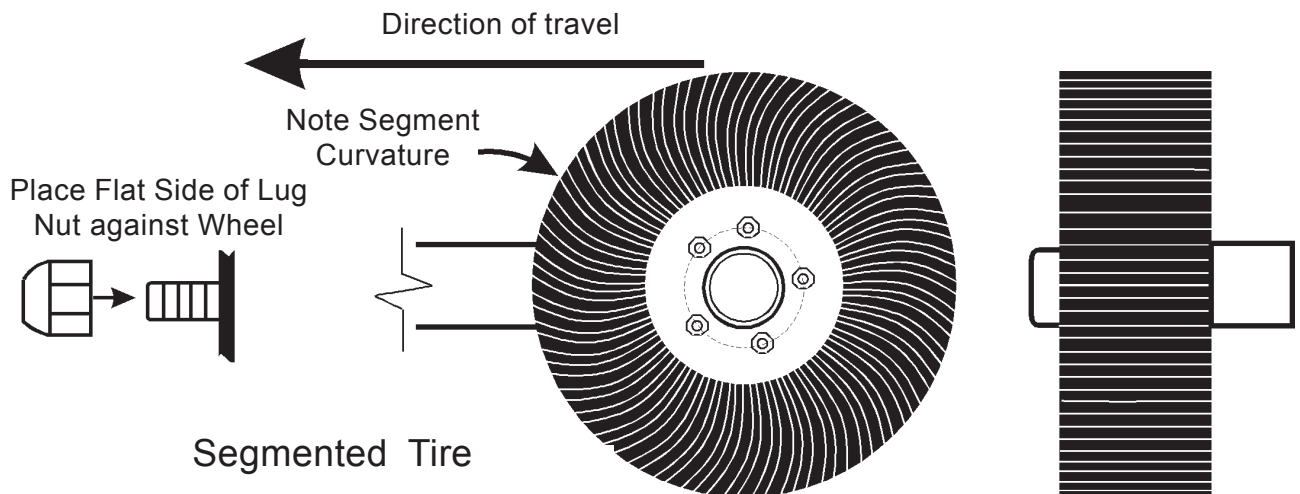

Jan. 2002  
to  
Current

## TIRES & WHEELS ST15 / ST10

ST15-C31200557203  
to  
ST15-Current

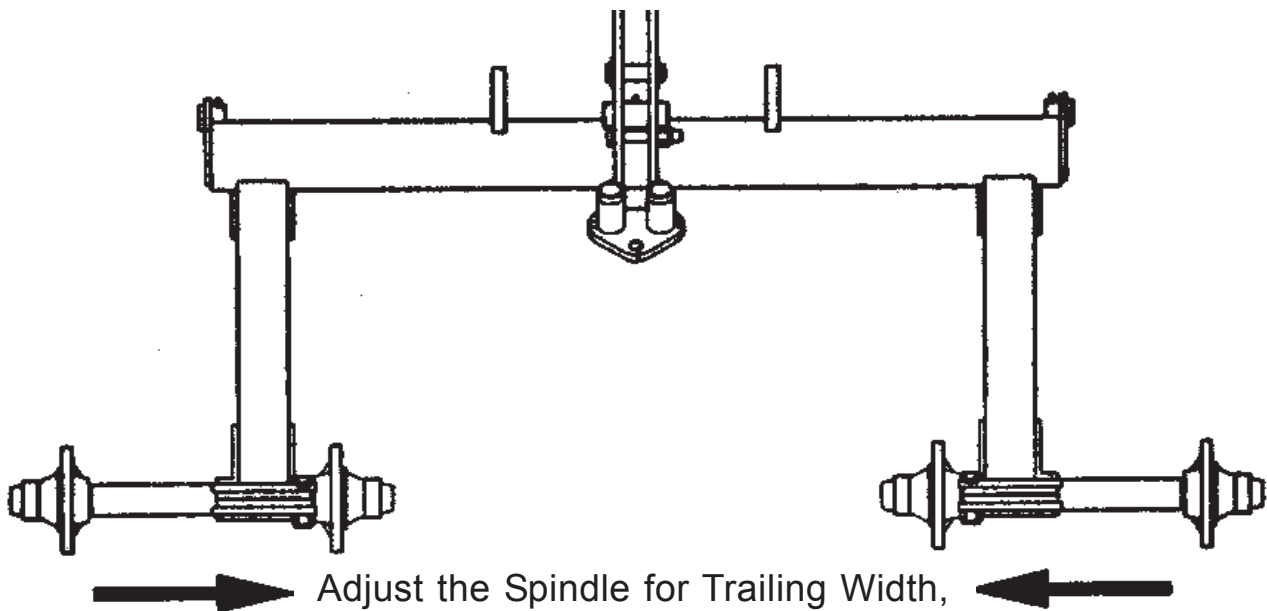

### **Adjust Center axle Spindles for Width:**

When the Spindles are installed and mower is being readied for use. The Spindles in the Center Axle need to be adjusted to give the desired trailing width, this determines where the Wheels run inline with the mower and the wheel track width. This will need to be done once and should not change unless it is unbolted and moved.

Jan. 2002  
to  
Current

# PTO DRIVELINE 540 RPM Cat V ST15 / ST10

ST15-C31200557203  
to  
ST15-Current

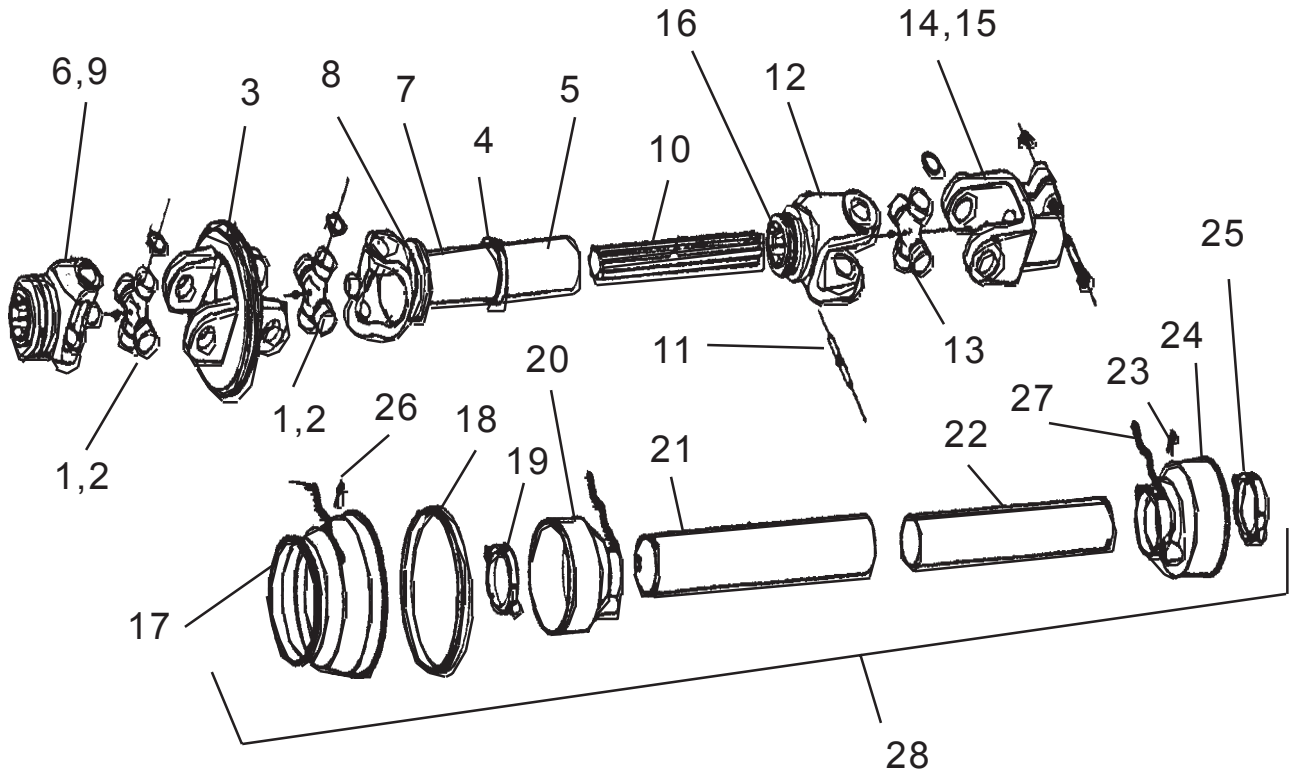

Item	Part No.	Qty.	Description	Item	Part No.	Qty.	Description
	02978692	1	Driveline Asy. (540)	14	02978677	1	Yoke
1	02978663	3	Grease Fitting	15	02978678	2	Bolt & Nut
2	02978664	2	Universal Joint	16	02978679	1	Male Shaft Asy.
3	02978665	1	Double Yoke	17	02978680	1	Cone Asy.
4	02978666	1	Shield support	18	02978681	1	Bearing
5	02978667	1	Grease Fitting	19	02978682	1	Retaining Collar
6	02978668	1	Yoke, w/ QD Collar	20	02978683	1	Outer Cone
7	02978669	1	Yoke & Sleeve Asy.	21	02978684	1	Shield, Outer
8	02978670	1	Shaft Asy, Outer	22	02978685	1	Shield, Inner
9	02978671	1	QD Collar Kit, Plastic	23	02978709	6	Bolt, Wing D/L
	02978672	1	QD Collar Kit, Steel	24	02978687	1	Inner Cone
10	02978673	1	Shaft, Splined	25	02978688	1	Retaining Collar
11	02978674	1	Roll Pin	26	02978689	6	Screw
12	02978675	1	Yoke, Inner	27	02978690	1	Safety Chain
13	02978676	1	Universal Joint	28	02978691	1	Shield Asy, Complete

NOTE: This is a Cat 5 Driveline used on 540 RPM Model and Some parts will not interchange with the Cat 4 used on the 1000 RPM Model. Check part numbers for intrchangable parts.



Jan. 2002  
to  
Current

## PTO DRIVELINE 1000 RPM Cat IV ST15 / ST10

ST15-C31200557203  
to  
ST15-Current

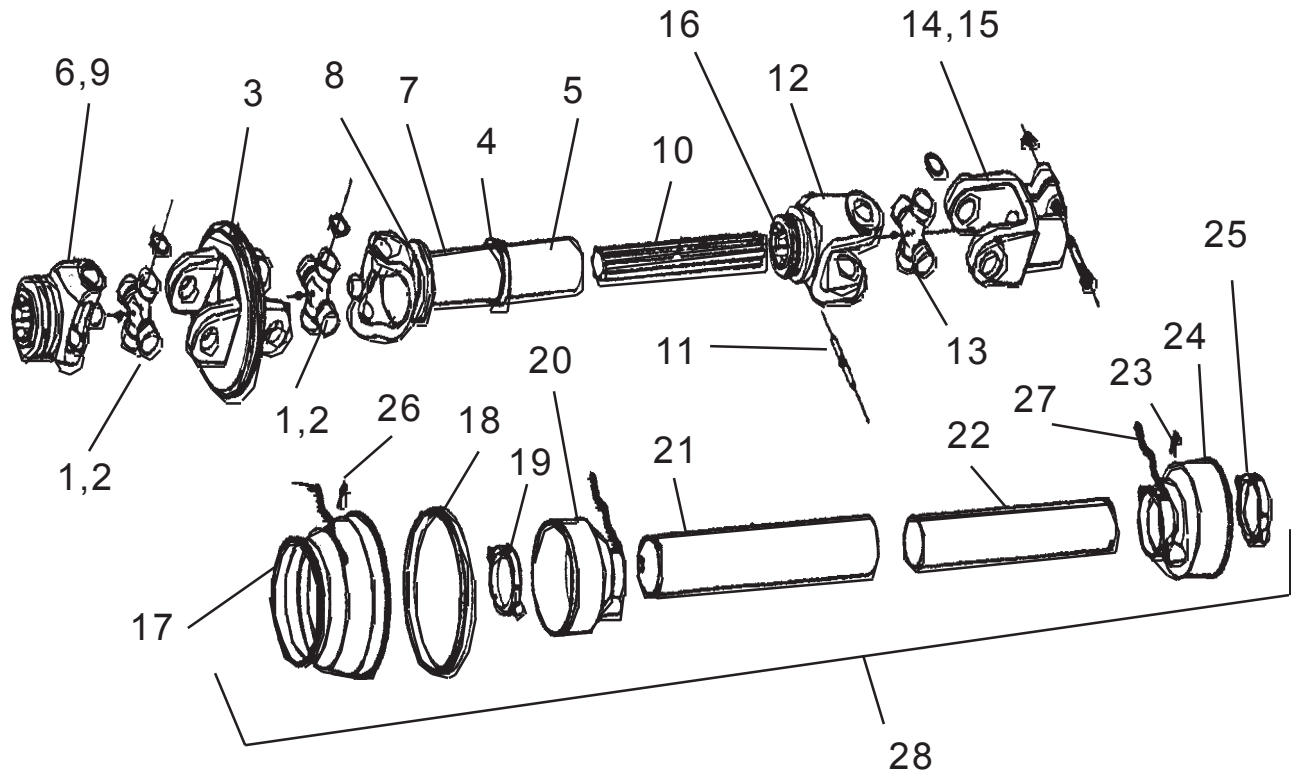

Item	Part No.	Qty.	Description	Item	Part No.	Qty.	Description
	02978949	1	Driveline Asy. (1000)	14	02978959	1	Yoke
1	02978663	3	Grease Fitting	15	02978678	2	Bolt & Nut
2	02978950	2	Universal Joint	16	02978960	1	Male Shaft Asy.
3	02978951	1	Double Yoke	17	02978961	1	Cone Asy.
4	02978952	1	Shield support	18	02978962	1	Bearing
5	02978667	1	Grease Fitting	19	02978707	1	Retaining Collar
6	02978953	1	Yoke, w/ QD Collar	20	02978963	1	Outer Cone
7	02978954	1	Yoke & Sleeve Asy.	21	02978964	1	Shield, Outer
8	02978955	1	Shaft Asy, Outer	22	02978965	1	Shield, Inner
9	02978671	1	QD Collar Kit, Plastic	23	02978709	6	Bolt, Wing D/L
	02978672	1	QD Collar Kit, Steel	24	02978966	1	Inner Cone
10	02978956	1	Shaft, Splined	25	02978713	1	Retaining Collar
11	02978957	1	Roll Pin	26	02978689	6	Screw
12	02978958	1	Yoke, Inner	27	02978690	1	Safety Chain
13	02978696	1	Universal Joint	28	02978967	1	Shield Asy, Complete

NOTE: This is a Cat 4 Driveline used on 1000 RPM Model and Some parts will not interchange with the Cat 5 used on the 540 RPM Model. Check part numbers for intrchangable parts.

Jan. 2002  
to  
Current

# WING DRIVELINE Cat IV (540 or 1000) ST15 / ST10

ST15-C31200557203  
to  
ST15-Current

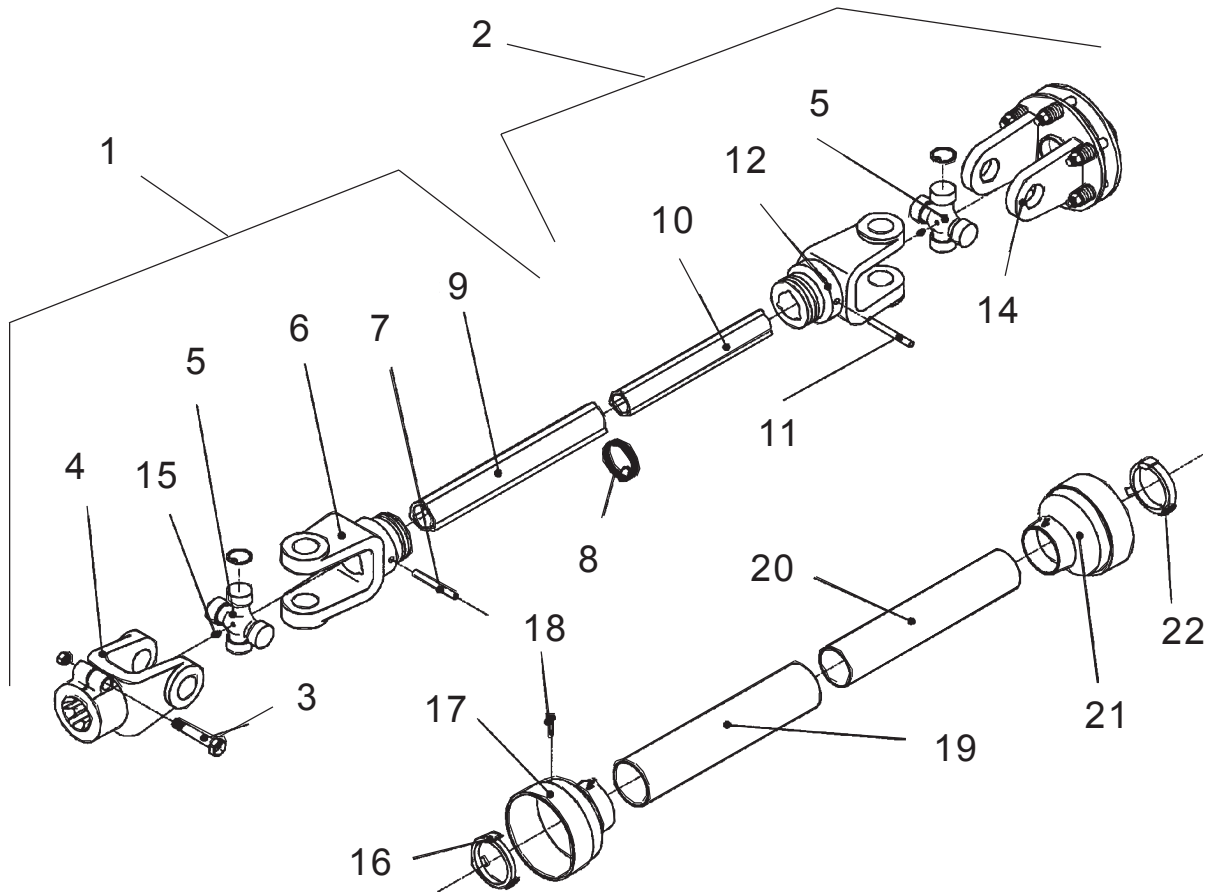

Item	Part No.	Qty.	Description	Item	Part No.	Qty.	Description
1.	02978693	1	Driveline Asy. Wing	11	02978702	1	Roll Pin
	02978705	1	Driveline Half Asy. Clamp Yoke End	12	02978703	1	Yoke, Inner
2.	02978706	1	Driveline Half Asy, Clutch End	13	02978667	1	Grease Fitting
3.	02978694	4	Bolt & Nut	14	02978704	1	Clutch Asy
4.	02978695	1	Clamp Yoke	15	02978663	2	Grease Fitting
5.	02978696	2	Universal Joint	16	02978707	1	Retaining Collar
6.	02978697	1	Yoke, Outer	17	02978708	1	Outer Cone
7.	02978698	1	Roll pin	18	02978709	6	Bolt
8.	02978699	1	Shield Support	19	02978710	1	Shield Asy, Outer
9.	02978700	1	Tube, Outer	20	02978711	1	Shield Asy, Inner
10.	02978701	1	Tube, Inner	21	02978712	1	Clutch Cone
				22	02678713	1	Retaining Collar

Jan. 2002  
to  
Current

# INTERMEDIATE DRIVELINE Cat IV (540 or 1000) ST15 / ST10

ST15-C31200557203  
to  
ST15-Current

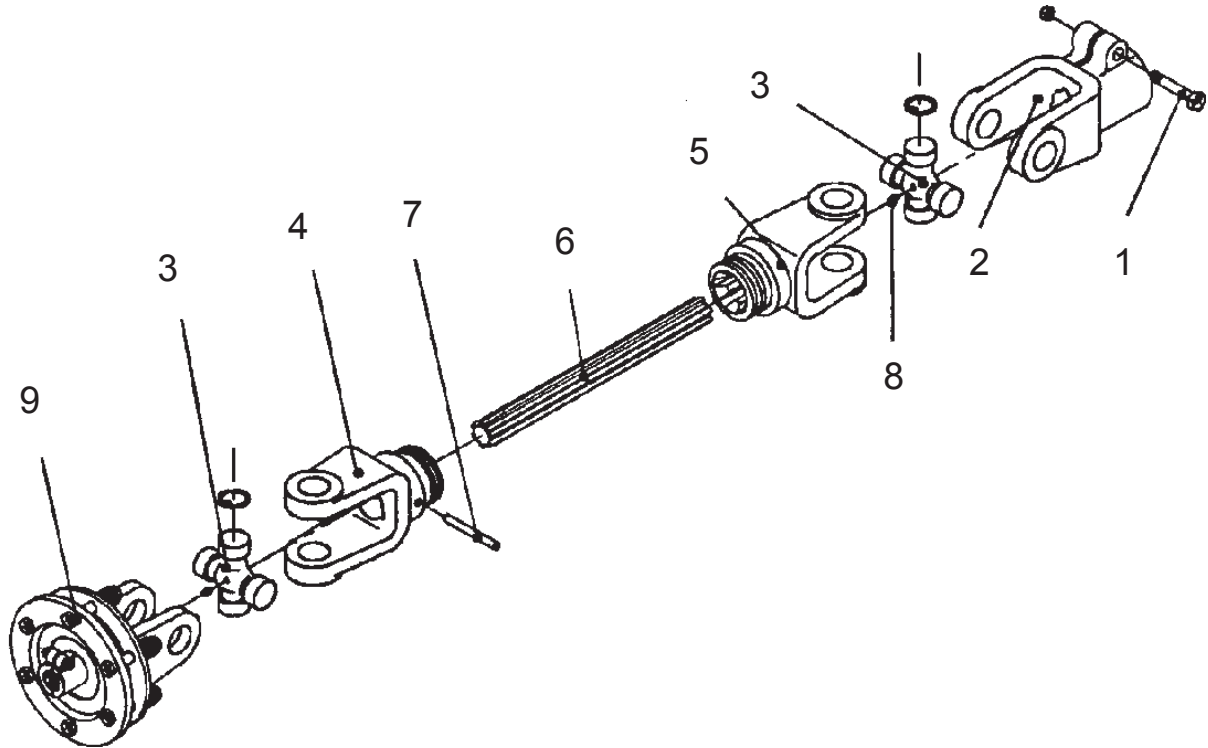

Item	Part No. 540 RPM	Part No. 1000 RPM	Qty.	Description
	02978714	-----	--	Driveline Asy, 540 RPM
	-----	02978993	--	Driveline Asy, 1000 RPM
1	02978694	02978694	1	Bolt & Nut
2	02978695	02978695	1	Clamp Yoke
3	02978696	02978696	2	Universal Joint (X-Kit)
4	02978716	02978716	1	Yoke, Pin Yoke
5	02978715	02978715	1	Yoke, Slip Yoke
6	02978717	02978717	1	Splined shaft
7	02978718	02978718	1	Spring Dowel Pin
8	02978663	02978663	2	Grease Fitting
9	02978704	-----	1	Slip Clutch Asy, 540 RPM
	-----	02978974	1	Slip Clutch Asy, 1000 RPM

Jan. 2002  
to  
Current

# SLIP CLUTCH Cat IV (540 RPM) ST15 / ST10

ST15-C31200557203  
to  
ST15-Current

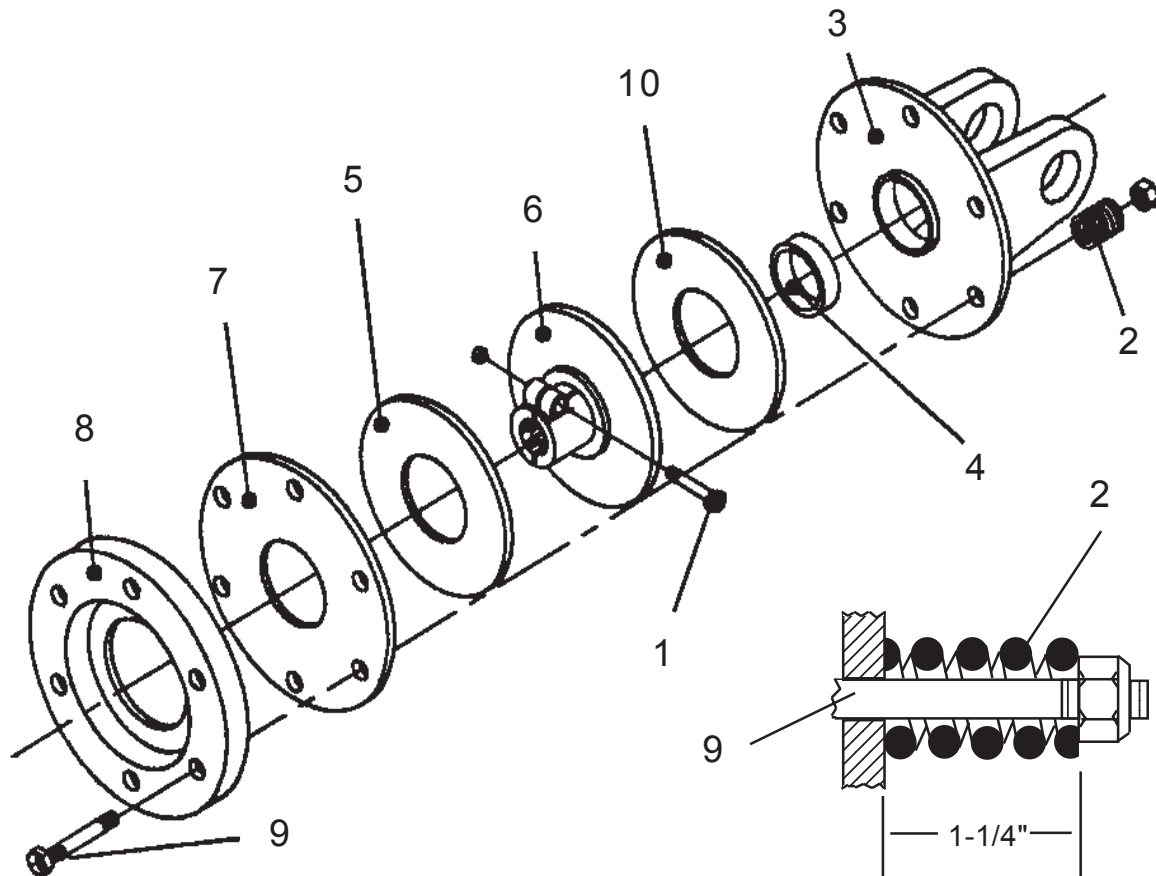

Item	Part No.	Qty.	Description
	<b>02978704</b>	-	<b>Clutch Asy, Center or Wing 540 RPM</b>
1	02978694	1	Bolt & nut
2	02978719	8	Spring
3	02978720	1	Flanged yoke
4	02978721	1	Bushing
5	00754202	2	Lining ring
6	02978723	1	Flange hub, 1 3/8x21
7	02978724	1	Inner plate
8	02978725	1	Pressure plate
9	02978726	8	Bolt & nut

NOTE: To adjust this Slip Clutch tighten Bolts, (item 9) until Springs, (item 2) are a compressed length of 1-1/4" as shown in drawing above. When tightening use an alternating pattern in a criss-cross pattern.

Jan. 2002  
to  
Current

# SLIP CLUTCH Cat IV (1000 RPM) ST15 / ST10

ST15-C31200557203  
to  
ST15-Current

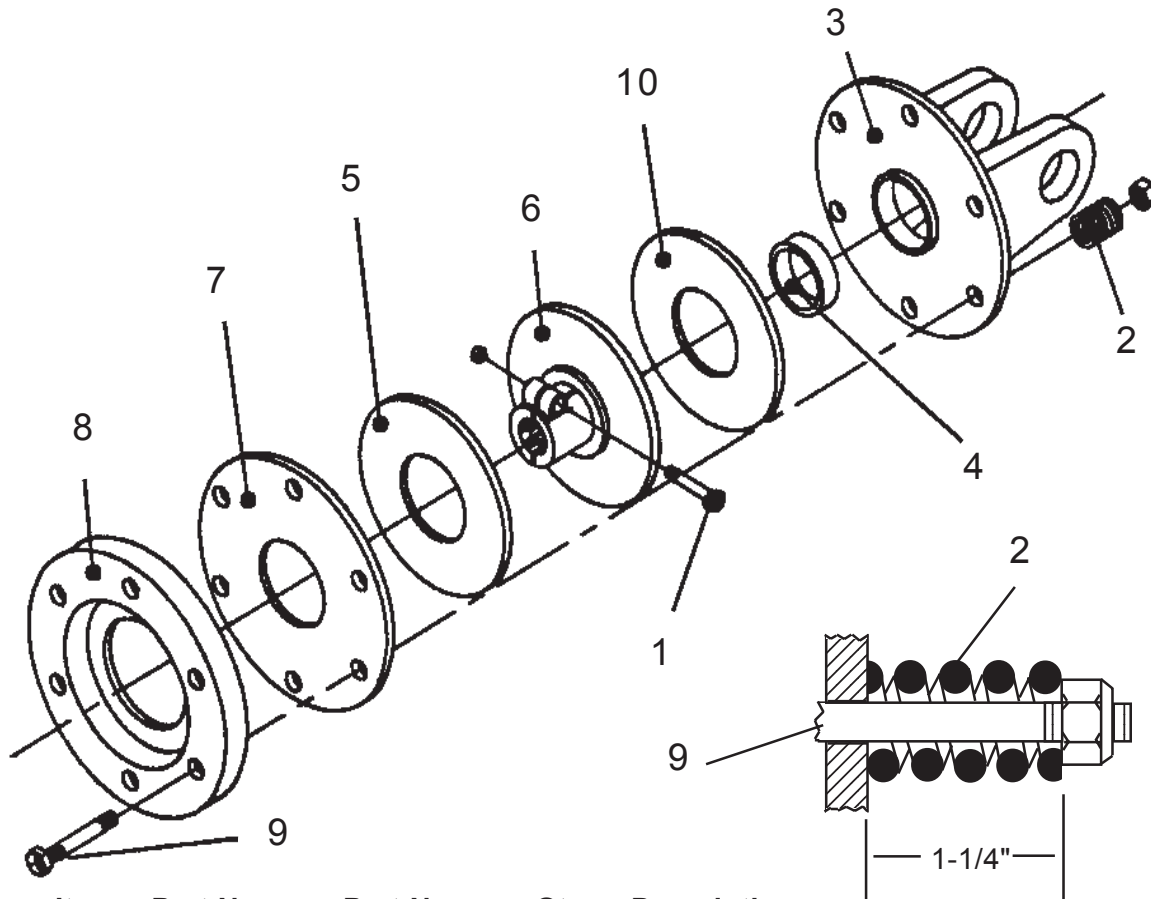

Item	Part No. Center	Part No Wings	Qty.	Description
	<b>02978974</b>	-----	-	<b>Slip Clutch Asy, Center 1000 RPM</b>
	-----	02878704	--	Slip Clutch Asy. Wing 1000 RPM
1	02978694	02978694	1	Bolt & nut
2	02978975	02978719	8	Spring
3	02978976	02978720	1	Flanged yoke
4	02978977	02978771	1	Bushing
5	02978978	00754202	2	Lining ring
6	02978979	02978723	1	Flange hub, 1 3/8x21
7	-----	-----	n/a	Not used on Asy # 02978974 at all
	-----	02978724	1	Inner Plate used on Wings Only
8	02978991	02978725	1	Pressure Plate
9	02978980	02978726	8	Bolt & nut

NOTE: To adjust this Slip Clutch tighten Bolts, (item 9) untill Springs, (item 2) are a compressed length of 1-1/4" as shown in drawing above. When tightening use an alternating pattern in a criss-cross pattern.

Jan. 2002  
to  
Current

# GEARBOX ASY. DIVIDER ST15 / ST10

ST15-C31200557203  
to  
ST15-Current

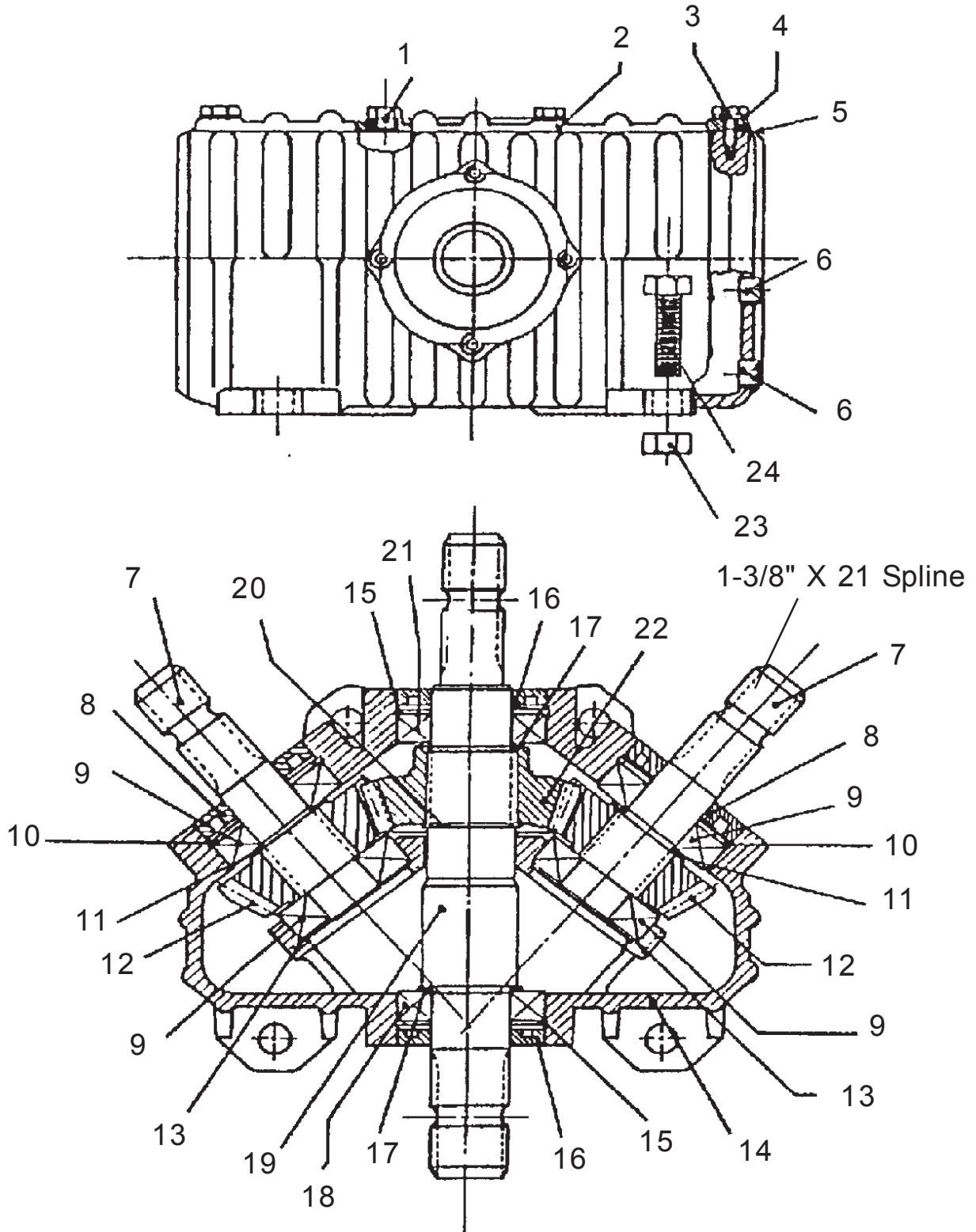

Jan. 2002  
to  
Current

## GEARBOX ASY. DIVIDER ST15 / ST10

ST15-C31200557203  
to  
ST15-Current

Item	Part No. 540 RPM	Part No. 1000 RPM	Qty.	Description
	02978514	-----	--	Gearbox Asy, Divider, 540 RPM
	-----	02978968	-	Gearbox Asy, Divider 1000 RPM
1	02978727	02978727	1	Oil Filler Plug,
2	02978728	02978728	1	Cover
3	02978729	02978729	6	Bolt
4	02978730	02978730	6	Spring washer
6	02978731	02978731	2	Plug, Oil Level
7	02978732	02978732	2	Shaft, 1-3/8" X 21 Spline
8	02978733	02978733	2	Oil seal
9	02978734	02978734	4	Bearing
10	02978735	02978735	2	Internal Circlip
12	02978736	-----	2	Gear, 540 RPM
	-----	02978969	2	Gear, 1000 RPM
13	02978737	02978737	2	Shim Kit
14	02978738	02978738	1	Casing
15	02978739	0297839	2	Internal Circlip
16	02978740	02978740	2	Seal
17	02978741	02978741	2	Shim
18	02978742	02978742	1	Bearing
19	02978743	02978743	1	Shaft
20	02978744	02978743	1	Shoulder ring
21	02978742	02978742	1	Bearing
22	02978746	-----	1	Gear, 540 RPM
	-----	02978970	1	Gear, 1000RPM
23	000944	000944	4	Lock Nut
24	00753753	00753753	4	Bolt

NOTE: Gearbox Gear ratio 1000 RPM is 1.35 in : 1 out and a 540 RPM is 1 in : 1.35 out.

Jan. 2002  
to  
Current

# GEARBOX ASY. CENTER DECK ST15 / ST10

ST15-C31200557203  
to  
ST15-Current

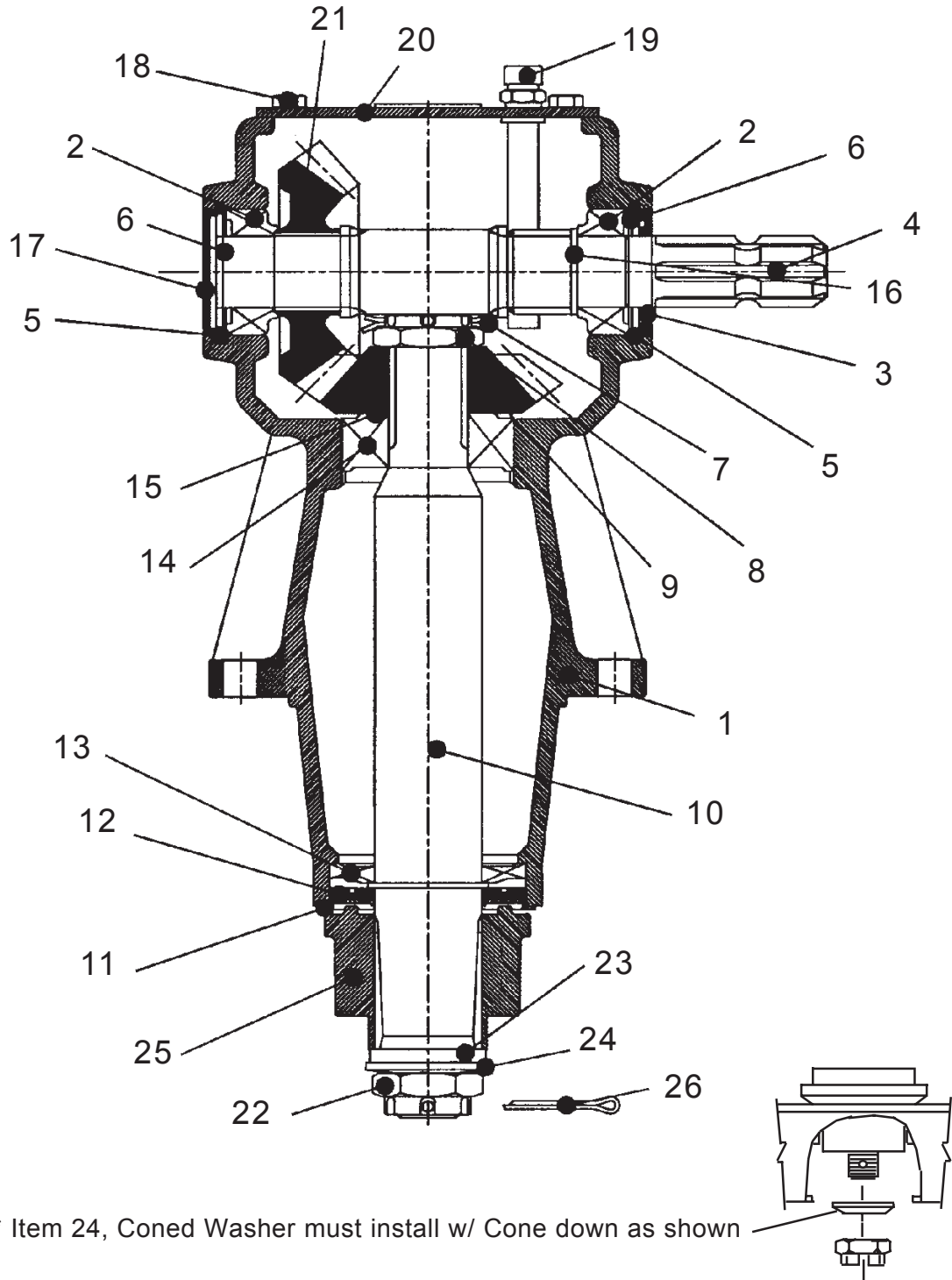

\* Item 24, Coned Washer must install w/ Cone down as shown



Jan. 2002  
to  
Current

## GEARBOX ASY. CENTER DECK ST15 / ST10

ST15-C31200557203  
to  
ST15-Current

Item	Part No. 540 RPM	Part No. 1000 RPM	Qty	Description
	02978513	-----	-	Gearbox Asy, 540 RPM
	-----	02978971	-	Gearbox Asy, 1000 RPM
1	02978747	02978747	1	Casing
2	02978748	02978748	2	Bearing
3	02978733	02978733	1	Seal
4	02978749	02978749	1	Shaft, Input
5	02978750	02978750	2	Snap Ring
6	02978751	02978751	2	Shim
7	02978752	02978752	1	Cotter Pin
8	02978753	02978753	1	Nut
9	02978754	-----	1	Gear, 540 RPM
	-----	02978972	1	Gear, 1000 RPM
10	02978758	02978758	1	Shaft
11	02978755	02978755	1	Sealing lid
12	02978756	02978756	1	Seal
13	02978757	02978757	1	Bearing
14	02978759	02978759	1	Bearing
15	02978760	02978760	1	Shim
16	02978761	02978761	1	Shim
17	02978762	02978462	1	Cap
18	02978763	02978763	4	Bolt
19	02978764	02978764	1	Plug
20	02978765	02978765	1	Cover
21	02978766	-----	1	Gear, 540 RPM
	-----	02978973	1	Gear, 1000 RPM
22	02978571	02978571	1	Nut, Slotted
23	02978569	02978569	1	Flatwasher
24	02978769	02978769	1	Washer, Disc Spring (Coned)
25	02978770	02978770	1	Splined Hub (Ref Only - weld on part)
26	02978572	02978572	1	Cotter pin

NOTE: Gearbox Gear ratio 1000 RPM is 1.2 in : 1 out and a 540 RPM is 1 in : 1.5 out.

Jan. 2002  
to  
Current

# GEARBOX ASY. RIGHT WING DECK ST15 / ST10

ST15-C31200557203  
to  
ST15-Current

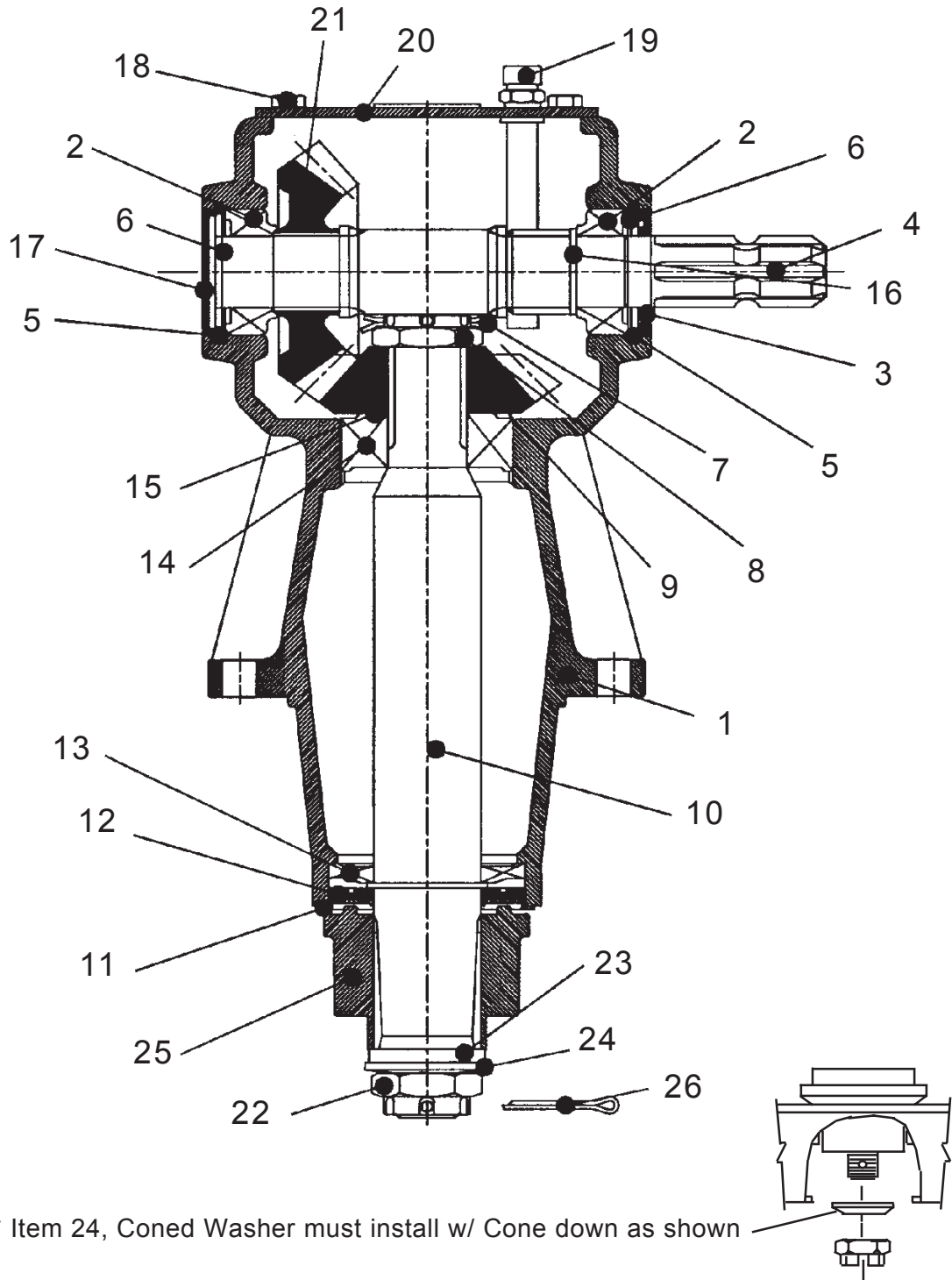

\* Item 24, Coned Washer must install w/ Cone down as shown

Jan. 2002  
to  
Current

## GEARBOX ASY. RIGHT WING DECK ST15 / ST10

ST15-C31200557203  
to  
ST15-Current

Item	Part No.	Qty	Description
	02978523	-	Gearbox Asy, 540 or 1000 RPM
1	02978747	1	Casing
2	02978748	2	Bearing
3	02978733	1	Seal
4	02978749	1	Shaft, Input
5	02978750	2	Snap Ring
6	02978751	2	Shim
7	02978752	1	Cotter Pin
8	02978753	1	Nut
9	02978772	1	Gear, 540 or 1000 RPM
10	02978758	1	Shaft
11	02978755	1	Sealing lid
12	02978756	1	Seal
13	02978757	1	Bearing
14	02978759	1	Bearing
15	02978760	1	Shim
16	02978761	1	Shim
17	02978762	1	Cap
18	02978763	4	Bolt
19	02978764	1	Plug
20	02978765	1	Cover
21	02978773	1	Gear, 540 or 1000 RPM
22	02978571	1	Nut, Slotted
23	02978569	1	Flatwasher
24	02978769	1	Washer, Disc Spring (Coned)
25	02978770	1	Splined Hub (Ref Only - weld on part)
26	02978572	1	Cotter pin

NOTE: Gearbox Gear ratio 540 or 1000 RPM is the same, 1 in : 1.35 out, the gear ratio between the 540 & 1000 RPM output will be determined by the Gear ratio of the divider Gearbox. Right and Left Wing Gearboxes use the same components, it is where the Input gear (item 21) & Top Cover (item 20) is installed that makes them different.

Jan. 2002  
to  
Current

# GEARBOX ASY. LEFT WING DECK ST15 / ST10

ST15-C31200557203  
to  
ST15-Current

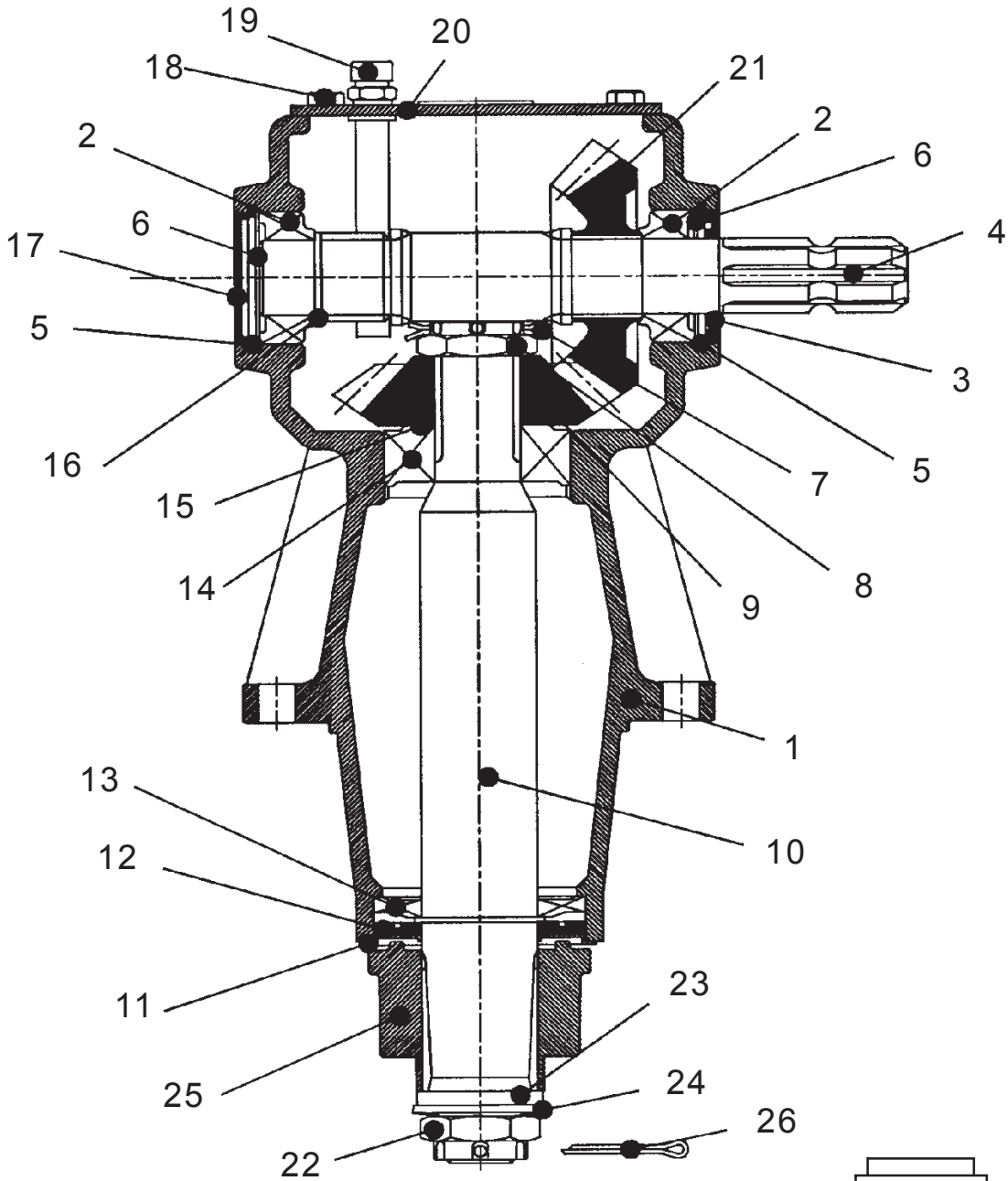

\* Item 24, Coned Washer must install w/ Cone down as shown

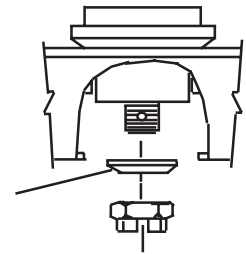

Jan. 2002  
to  
Current

## GEARBOX ASY. LEFT WING DECK ST15 / ST10

ST15-C31200557203  
to  
ST15-Current

Item	Part No.	Qty	Description
	02978533	-	Gearbox Asy, 540 or 1000 RPM
1	02978747	1	Casing
2	02978748	2	Bearing
3	02978733	1	Seal
4	02978749	1	Shaft, Input
5	02978750	2	Snap Ring
6	02978751	2	Shim
7	02978752	1	Cotter Pin
8	02978753	1	Nut
9	02978772	1	Gear, 540 or 1000 RPM
10	02978758	1	Shaft
11	02978755	1	Sealinglid
12	02978756	1	Seal
13	02978757	1	Bearing
14	02978759	1	Bearing
15	02978760	1	Shim
16	02978761	1	Shim
17	02978762	1	Cap
18	02978763	4	Bolt
19	02978764	1	Plug
20	02978765	1	Cover
21	02978773	1	Gear, 540 or 1000 RPM
22	02978571	1	Nut, Slotted
23	02978569	1	Flatwasher
24	02978769	1	Washer, Disc Spring (Coned)
25	02978770	1	Splined Hub (Ref Only - weld on part)
26	02978572	1	Cotter pin

NOTE: Gearbox Gear ratio 540 or 1000 RPM is the same, 1 in : 1.35 out, the gear ratio between the 540 & 1000 RPM output will be determined by the Gear ratio of the divider Gearbox. Right and Left Wing Gearboxes use the same components, it is where the Input gear (item 21) & Top Cover (item 20) is installed that makes them different.

Jan. 2002  
to  
Current

# GEARBOX SHIELDS ST15 / ST10

ST15-C31200557203  
to  
ST15-Current

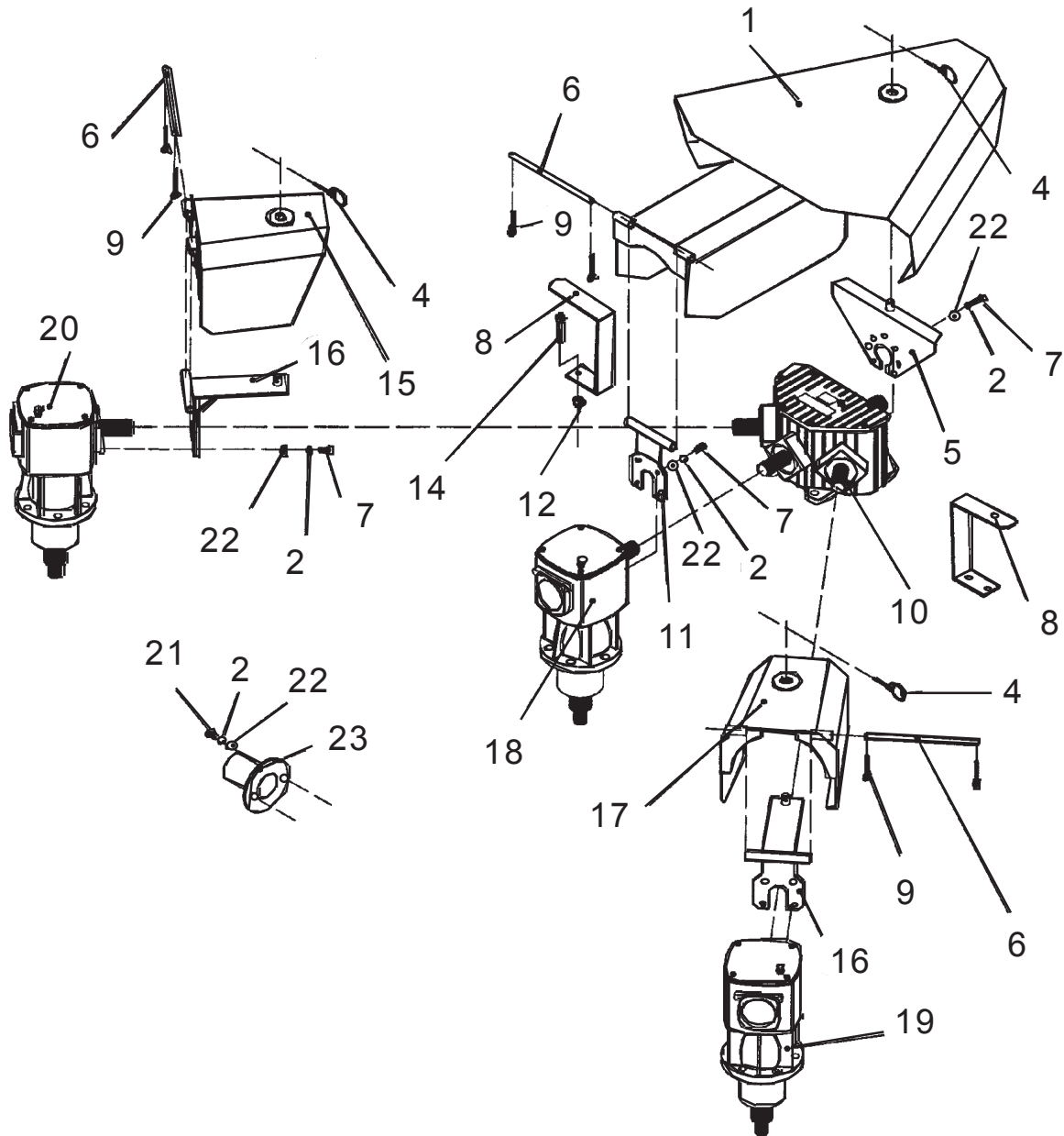

Jan. 2002  
to  
Current

## GEARBOX SHIELDS ST15 / ST10

ST15-C31200557203  
to  
ST15-Current

Item	Part No.	Qty.	Description
1	02978599	1	Center Section Shield Asy.
2	00011700	17	Lockwasher
4	02978510	3	Lynch Pin
5	02978600	1	Splitter Shield Mount
6	02978601	3	Shield Hinge Pin
7	02972026	15	Bolt
8	02978602	2	Splitter Shield Rest Bracket
9	40010000	6	Cotter Pin
10	02978514	1	Splitter Gearbox, 540 RPM
	02978968	1	Splitter Gearbox, 1000 RPM
11	02978603	1	CenterGearbox Pivot Shield Mount
12	00015800	4	Lock Nut
13	15B600	4	Flatwasher
14	00059900	4	Bolt
15	02978604	1	Left Wing Gearbox Pivot Shield
16	02978605	2	Wing Gearbox Pivot Mount
17	02978606	1	Right Wing Gearbox Shield
18	02978513	1	540 RPM Gearbox, CW
	02978971	1	1000 RPM Gearbox, CW
19	02978523	1	540 & 1000 RPM Gearbox, CCW
20	02978533	1	540 & 1000 RPM Gearbox, CW
21	00035900	2	Bolt
22	00023500	17	Flat washer
23	02978607	1	Shaft Cover Plastic, 10' Units Only

Jan. 2002  
to  
Current

# BLADE CARRIERS ST15 / ST10

ST15-C31200557203  
to  
ST15-Current

Left Wing  
CW Rotation

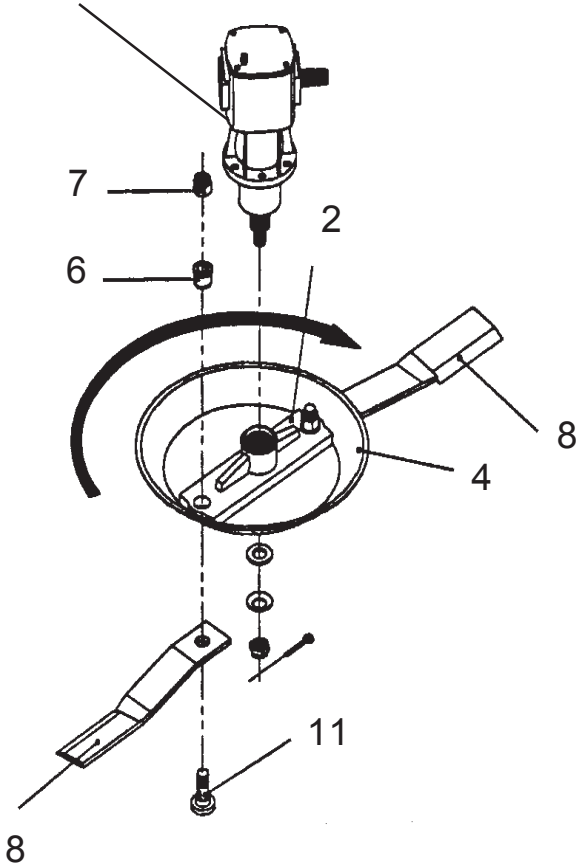

Center Section  
CW Rotation

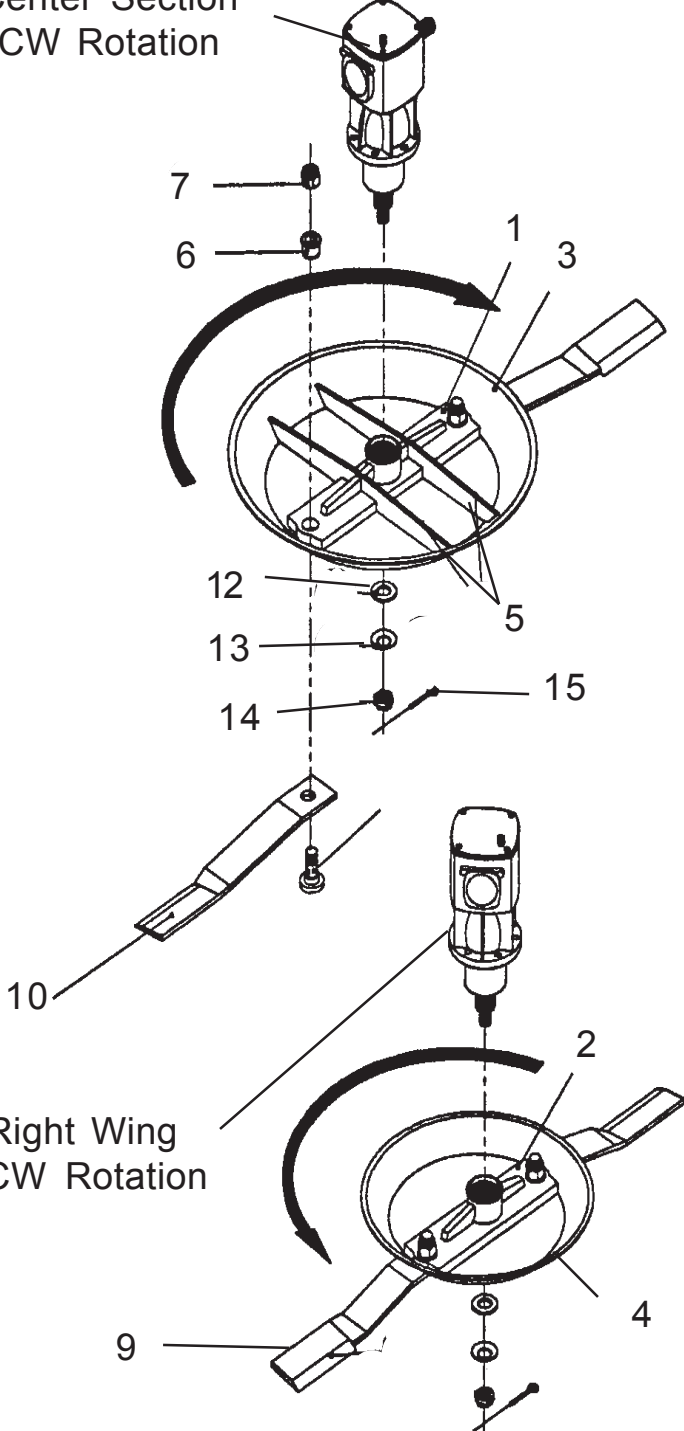

Right Wing  
CCW Rotation

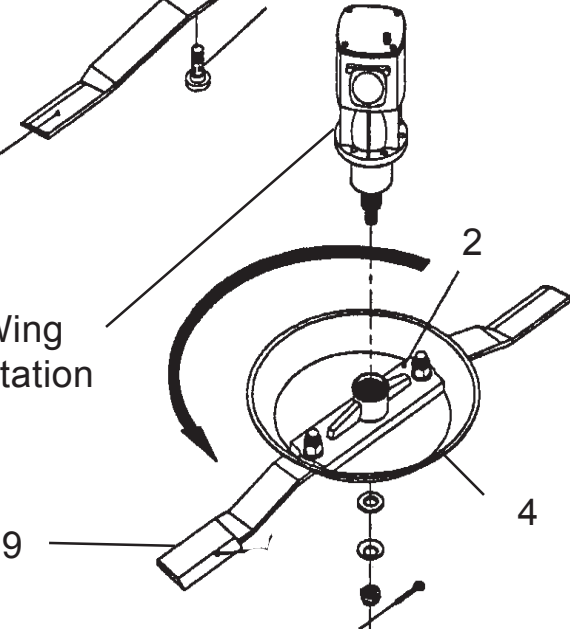



Jan. 2002  
to  
Current

## BLADE CARRIERS ST15 / ST10

ST15-C31200557203  
to  
ST15-Current

Item	Part No.	Qty.	Description
1	02978558	1	Blade Carrier & Pan,Center, (w/ item 3 & 6)
2	02978559	2	Blade Carrier & Pan, Wing, (w/ item 4)
3	02978560	1	Pan Only, Center Section Only
4	02978561	2	Pan Only, Left or Right Wing
5	02978562	2	Pan Reinforcements, Center Pan Only
6	02978563	6	Bushing, Blade Bolt
7	02978796	6	Locknut, f/ Blade Bolt
8	02978564	2	Blade, CW - Wing
9	02978565	2	Blade, CCW - Wing
10	02978566	2	Blade, CW - Center
11	02978567	6	Blade Bolt
	02978568	6	Blade Bolt & Nut ( w/ item 7)
12	02978569	3	Flatwasher
13	02978570	3	Washer
14	02978571	3	Nut, Slotted
15	02978572	3	Cotter Pin

Jan. 2002  
to  
Current

# BLADE CARRIER ROTATION ST15 / ST10

ST15-C31200557203  
to  
ST15-Current

ST15 (15')

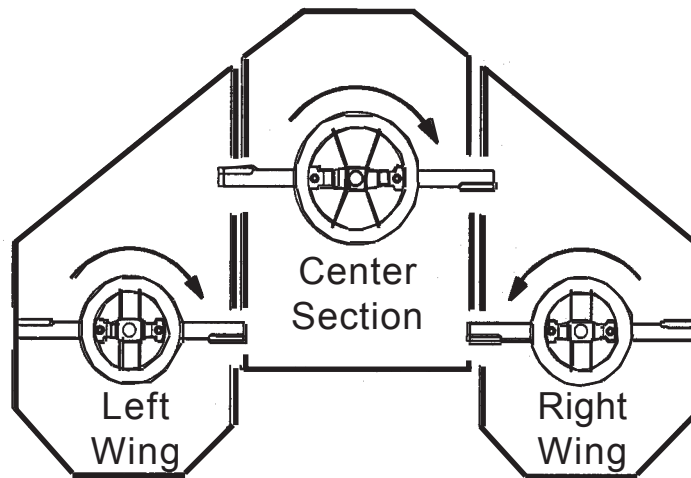

ST10 (10')

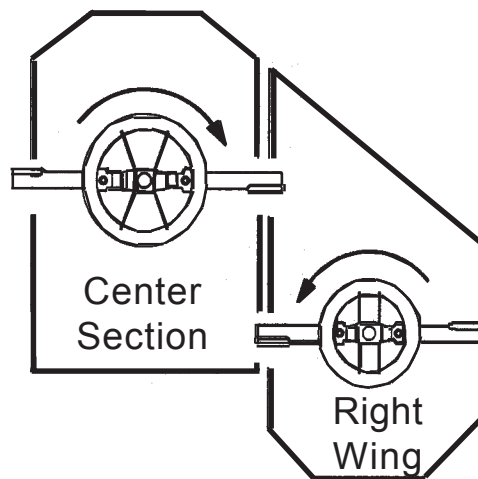

Jan. 2002  
to  
Current

## WINCH & STAND ST15 / ST10

ST15-C31200557203  
to  
ST15-Current

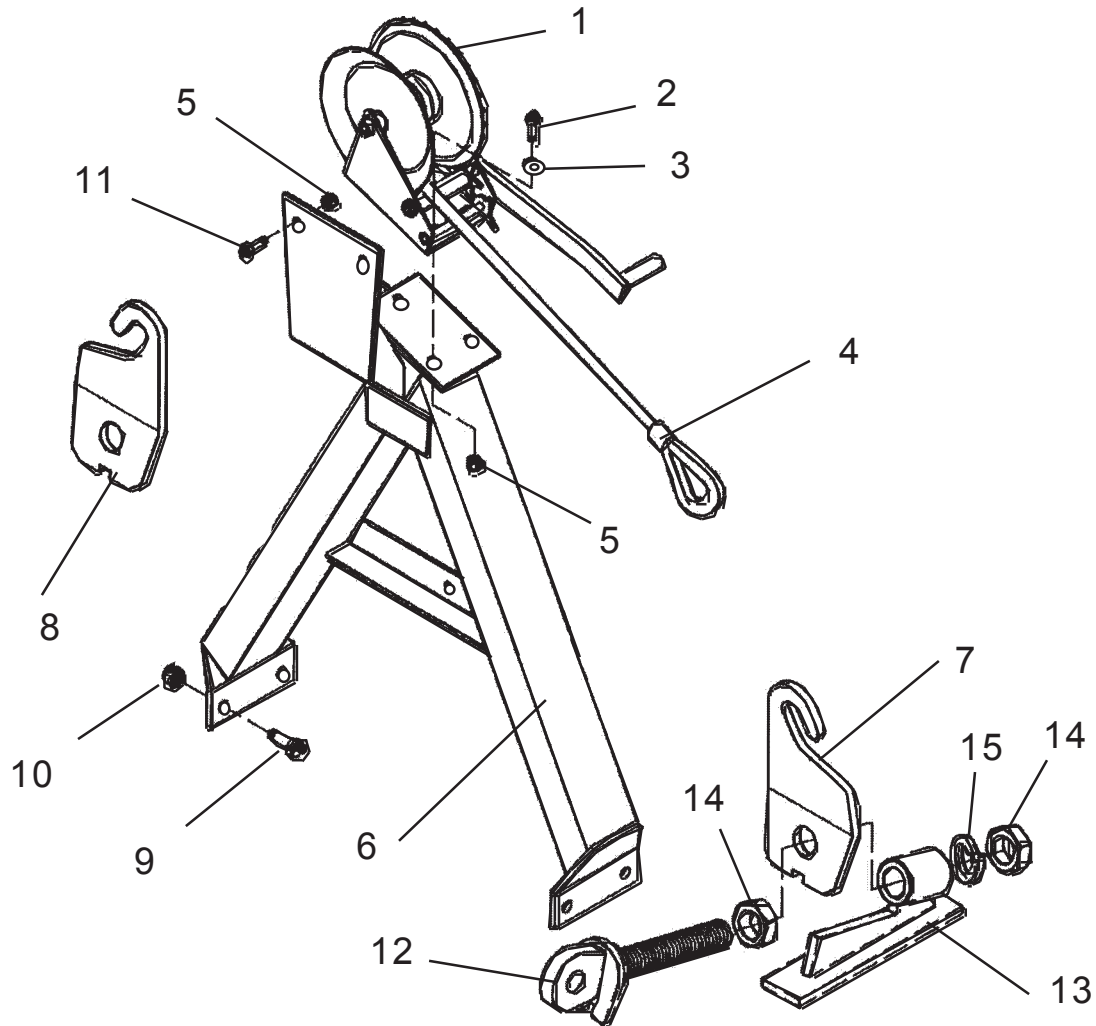

Item	Part NO.	Qty	Description
	02978897	--	Winch & Stand Kit (Optional)
1	02978933	1	Winch, 1600 lb., 5.1:1 ratio
2	00753642	3	Bolt
3	15B600	3	Flat Washer
4	02978934	1	Cable
5	00015800	5	Lock Nut
6	02978935	1	Winch Lift Stand
7	02978936	1	Winch Lift Lug, Right
8	02978937	1	Winch Lift Lug, Left
9	02776600	4	Bolt
10	00001800	4	Lock Nut
11	10180500	2	Bolt

NOTE: Items 12 through 15 are not included in Winch Kit # 02978897, they are already on the Wing Section of mower as part of Wing Axle. See Deck Components Section for these parts

Jan. 2002  
to  
Oct. 2003

# AXLE LIFT CYL. SCHEMATIC ST15 / ST10

ST15-C3120057203  
to  
ST15-C31200789311

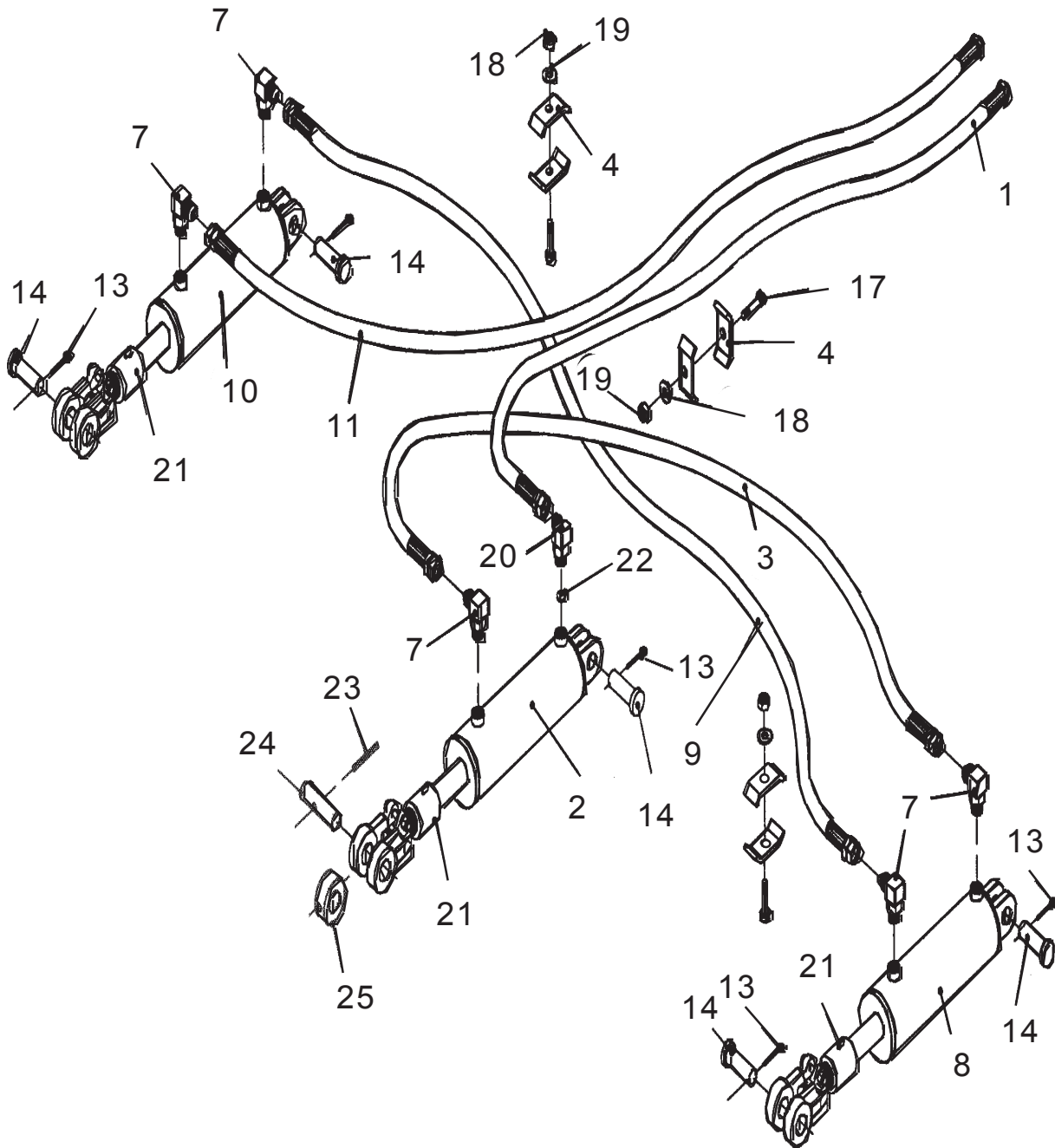

Jan. 2002  
to  
Oct. 2003

## AXLE LIFT CYL. SCHEMATIC ST15 / ST10

ST15-C31200557203  
to  
ST15-C31200789311

Item	Part No.	Qty.	Description
1	02978633	1	Hose Asy.
2	02978636	1	Cylinder Asy. Large Bore
3	02978637	1	Hose Assembly
4	02978638	6	Hose Clamp, Metal
7	02978616	5	Elbow
8	02978639	1	Cylinder Asy. Medium Bore
9	02978640	1	Hose Asy.
10	02978641	1	Cylinder Asy. Small Bore
11	02978642	1	Hose Asy.
13	00755153	6	Cotter Pin
14	02978527	6	Clevis Pin
17	02957042	1	Bolt
18	15B600	3	Flat Washer
19	00015800	3	Locknut
20	02978643	1	Elbow
21	02978655	3	Stroke Control Asy.
22	02978618	1	Restrictor
23	262-004	1	Roll Pin
24	C502-193	1	Cylinder Pin (Center)
25	C502-194	1	Cylinder Pin Sleeve

NOTE: These are Phasing (Slave) Cylinders and must be connected as shown, Large Bore Cylinder, Medium Bore Cylinder and then Small Bore Cylinder. The Cylinders will have to be free of Air, this means cylinders must be bled and remain an air tight system to prevent air from entering cylinders. See Operators manual for procedures to connect these cylinders. See drawing below showing how oil is bypassed through the Cylinder to the next Cylinder when Cylinders are stroked completely out.

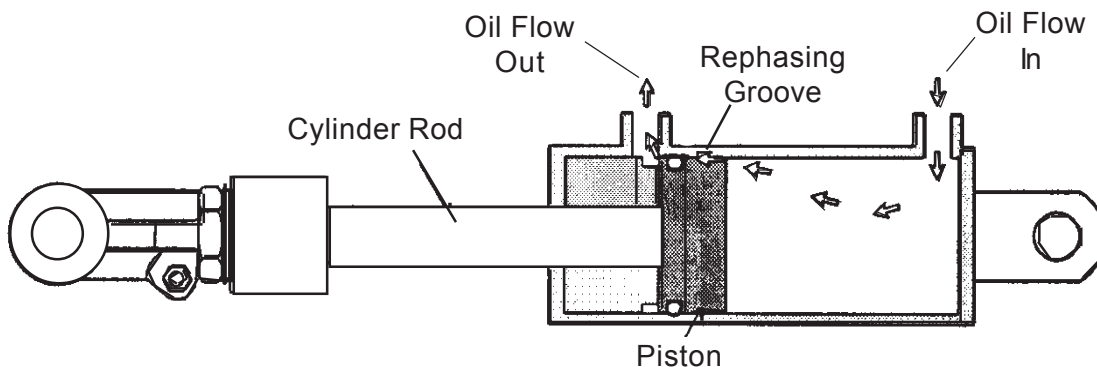

Nov. 2003  
to  
Current

# AXLE LIFT CYL. SCHEMATIC ST15 / ST10

ST15-C31200790311  
to  
ST15-Current

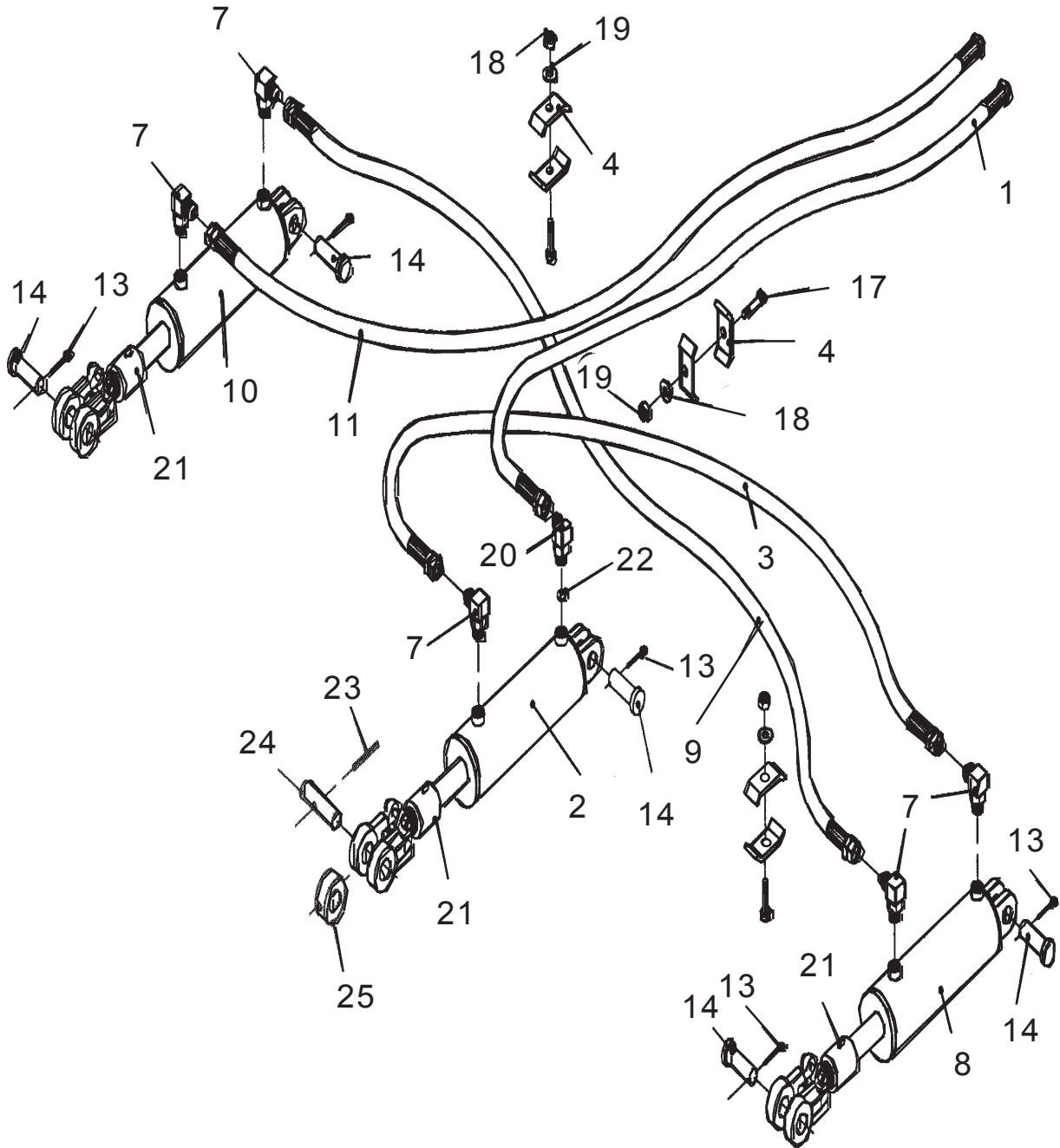

Nov. 2003  
to  
Current

## AXLE LIFT CYL. SCHEMATIC ST15 / ST10

ST15-C31200790311  
to  
ST15-Current

Item	Part No.	Qty.	Description
1	02978633	1	Hose Asy.
2	02980479	1	Cylinder Asy. Large Bore
3	02978637	1	Hose Assembly
4	02978638	6	Hose Clamp, Metal
7	02978616	5	Elbow
8	02980480	1	Cylinder Asy. Medium Bore
9	02978640	1	Hose Asy.
10	02980481	1	Cylinder Asy. Small Bore
11	02978642	1	Hose Asy.
13	00755153	6	Cotter Pin
14	02978527	6	Clevis Pin
17	02957042	1	Bolt
18	15B600	3	Flat Washer
19	00015800	3	Locknut
20	02978643	1	Elbow
21	02978655	3	Stroke Control Asy.
22	02978618	1	Restrictor
23	262-004	1	Roll Pin
24	C502-193	1	Cylinder Pin (Center)
25	C502-194	1	Cylinder Pin Sleeve

NOTE: These are Phasing (Slave) Cylinders and must be connected as shown, Large Bore Cylinder, Medium Bore Cylinder and then Small Bore Cylinder. The Cylinders will have to be free of Air, this means cylinders must be bled and remain an air tight system to prevent air from entering cylinders. See Operators manual for procedures to connect these cylinders. See drawing below showing how oil is bypassed through the Cylinder to the next Cylinder when Cylinders are stroked completely out.

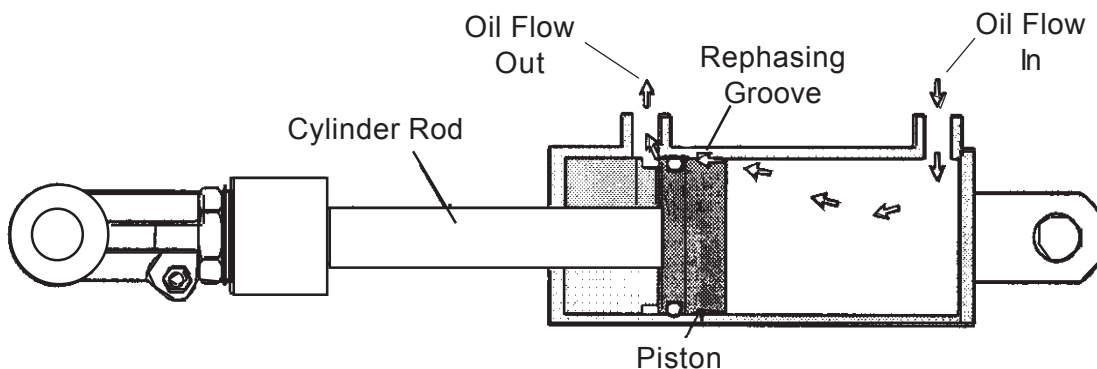

Jan. 2002  
to  
Oct. 2003

## AXLE LIFT CYL. ST15 / ST10

ST15-C31200557203  
to  
ST15-C31200789311

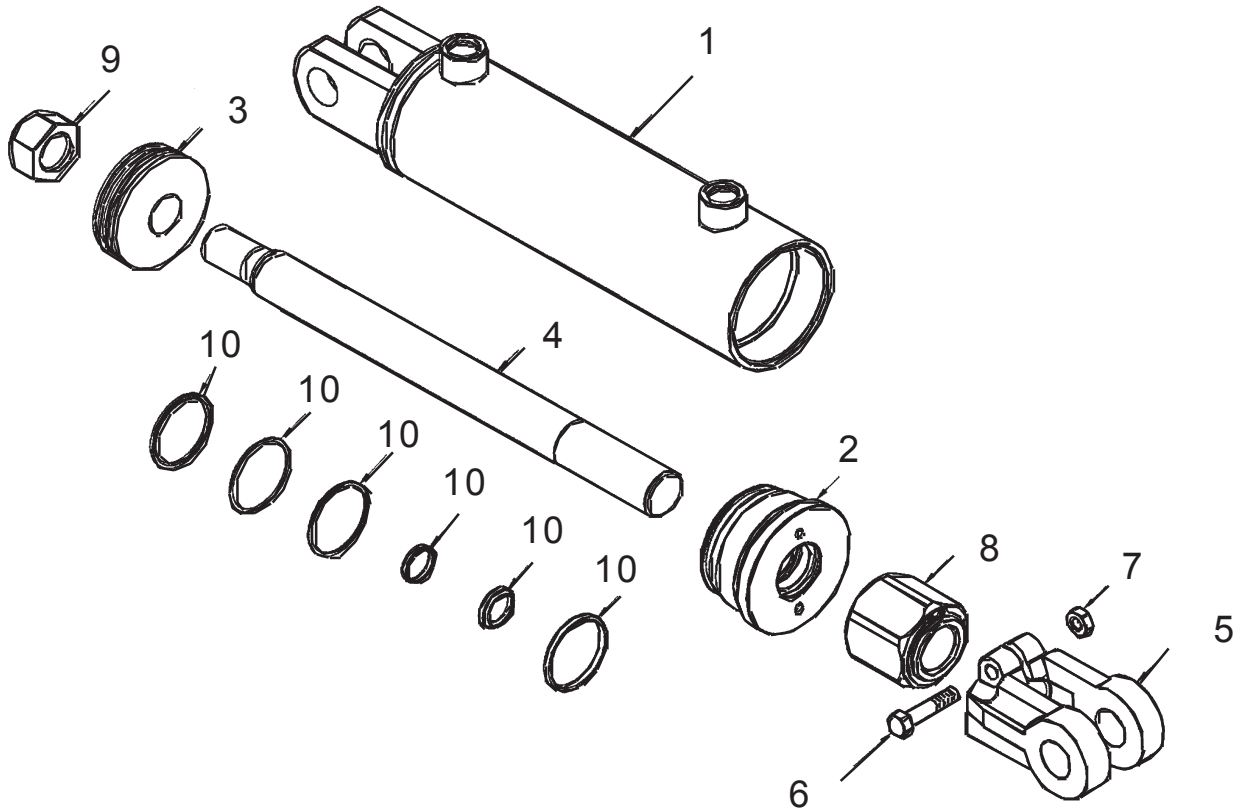

Item	Part No. L-Wing	Part No. R-Wing	Part No. Center	Qty	Description
1.	02978641	-----	-----	1	Cyl. Asy. 3" Bore X 5" Stroke
	-----	02978657	-----	1	Cyl. Asy. 3-1/4" Bore X 5" Stroke
	-----	-----	02978660	1	Cyl. Asy. 3-1/2" Bore X 5" Stroke
2.	02978650	02978657	02978661	1	Cyl. Barrell
3.	02978652	02978659	02978662	1	Piston
4.	02978653	02978653	02978653	1	Rod
5.	02978654	02978654	02978654	1	Rod Clevis
6.	02957042	02957042	02957042	1	Bolt
7.	00015800	00015800	00015800	1	Locknut
8.	02978655	02978655	02978655	1	Stroke Control Asy.
9.	02030300	02030300	02030300	1	Locknut
10.	02978656	02978689	02978990	1	Seal Kit

NOTE: These are Phasing Cylinders and must be connected in the correct order to work correctly. Seal Kit components not available as single parts.



Nov. 2003  
to  
Current

## AXLE LIFT CYL. ST15 / ST10

ST15-C31200790311  
to  
ST15-Current

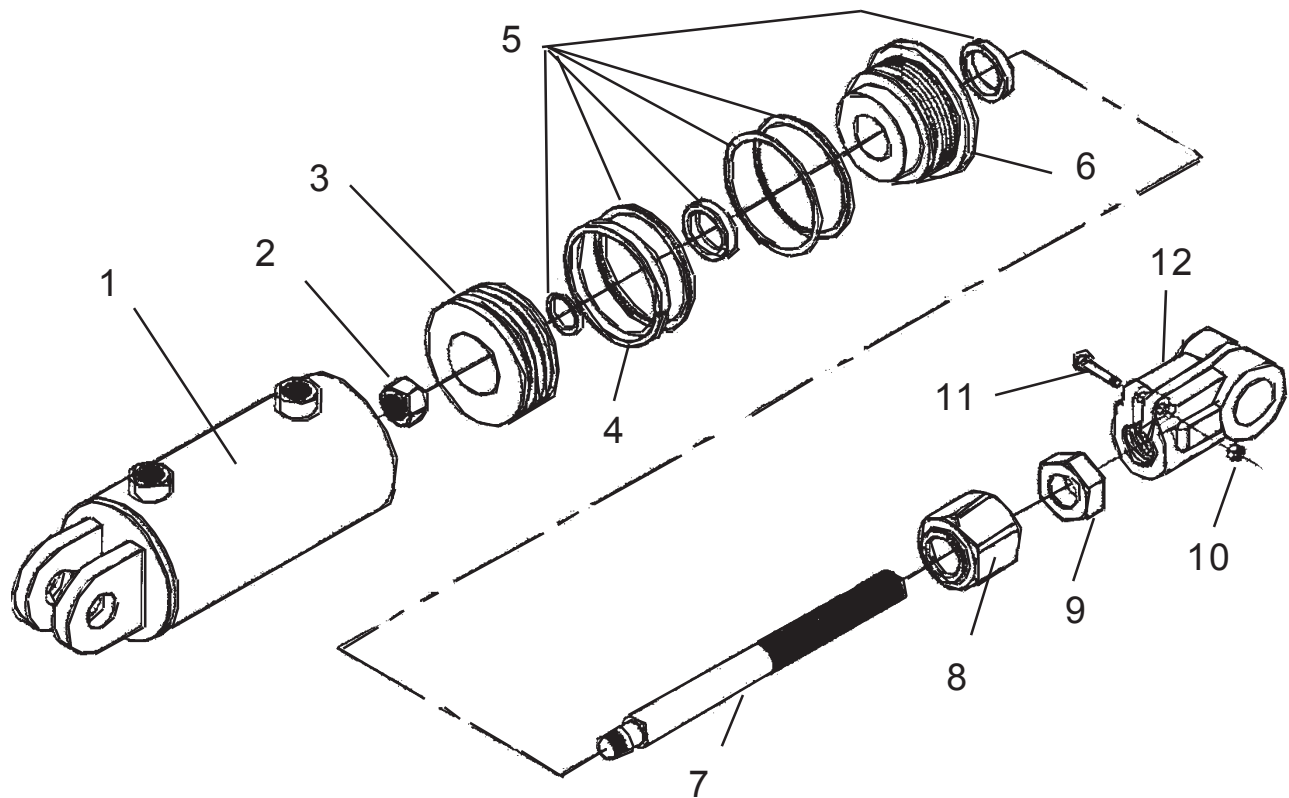

Item	Part No. L-Wing	Part No. R-Wing	Part No. Center	Qty	Description
	02980481	-----	-----	1	Cyl. Asy. 3" Bore X 5" Stroke
	-----	02980480	-----	1	Cyl. Asy. 3-1/4" Bore X 5" Stroke
	-----	-----	02980479	1	Cyl. Asy. 3-1/2" Bore X 5" Stroke
1.	02980482	02980489	02980494	1	Cyl. Barrell
2.	02980476	02980476	02980476	1	Piston Nut
3.	02980483	02980490	02980495	1	Piiston
4.	02980484	02980491	02980496	1	Wear Ring
5.	02980485	02980492	02980497	1	Seal Kit
6.	02980475	02980493	02980498	1	Gland
7.	02980486	02980486	02980486	1	Rod
8.	02978655	02978655	02978655	1	Stroke Control Asy.
9.	02980487	02980487	02980487	1	Jam Nut
10.	00750940	00750940	00750940	1	Nut
11.	00016200	00016200	00016200	1	Bolt
12.	02980488	02980488	02980488	1	Clevis End

Jan. 2002  
to  
Nov. 2003

# HYD SCHEMATIC WING LIFT CYL. ST15 / ST10

ST15-C31200557203  
to  
ST15-C312007890311

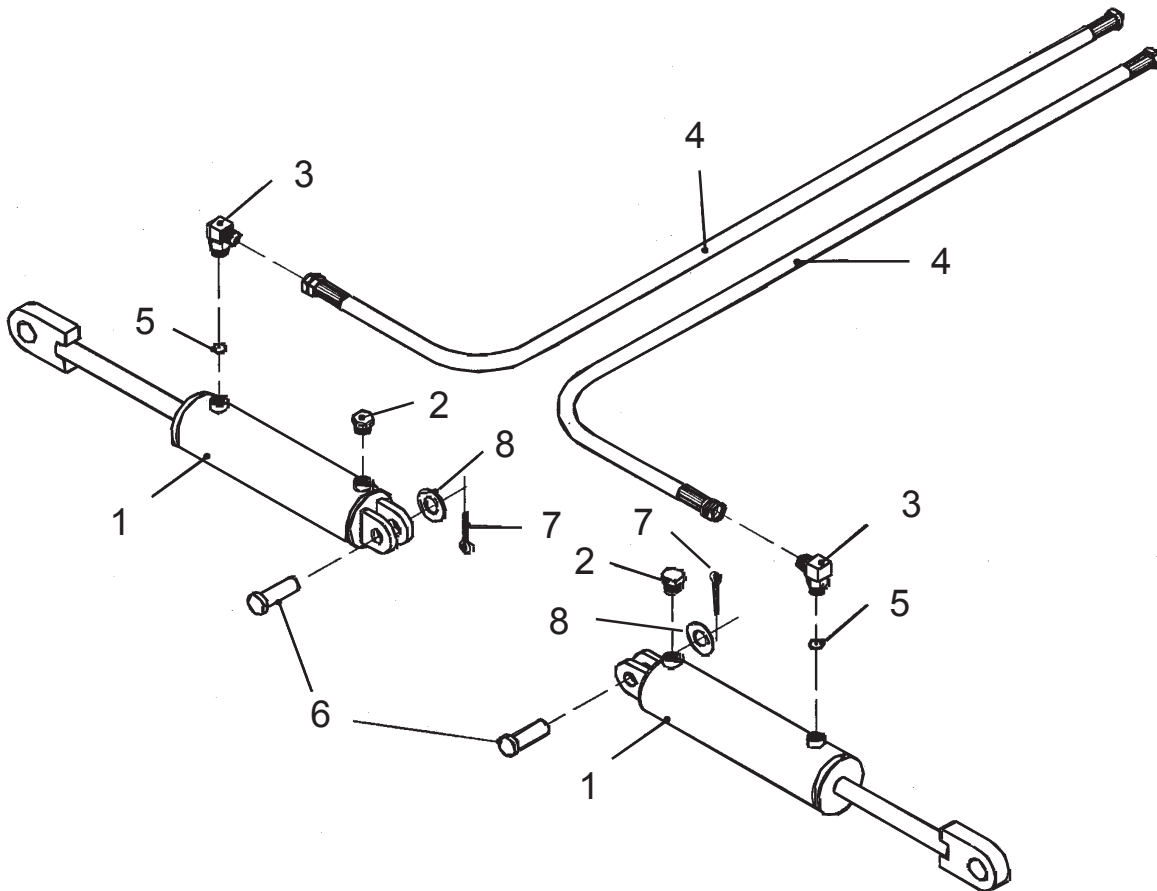

Item	Part No.	Qty	Description
1	02978614	2	Cylinder Asy. 3" Bore x 12" Stroke
2	02978615	2	Breather, Filter
3	02978616	2	Elbow
4	02978617	2	Hose Asy.
5	02978618	2	Restrictor
6	02978527	2	Clevis Pin
7	00755153	2	Cotter Pin,
8	15B1600	2	Flatwasher

Nov. 2003  
to  
Current

# HYD SCHEMATIC WING LIFT CYL. ST15 / ST10

ST15-C31200790311  
to  
ST15-Current

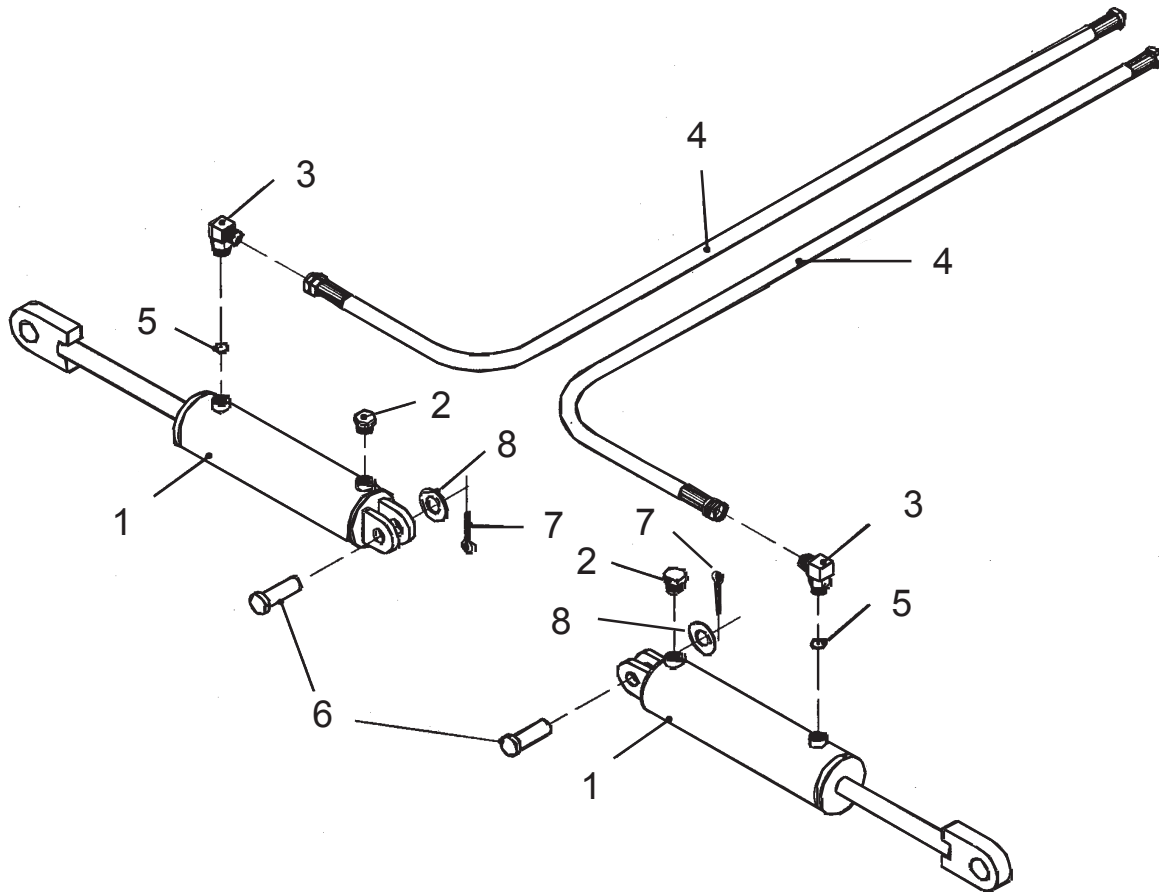

ITEM	PART NO.	QTY.	DESCRIPTION
1	02980472	2	Cylinder 3 x 12
2	02978615	2	Breather, filter
3	02978616	2	Elbow
4	02978617	2	Hose assembly
5	02978618	2	Restrictor
6	02978527	2	Clevis pin
7	00755153	2	Cotter pin,
8	15B1600	2	Flat washer

Jan. 2002  
to  
Oct. 2003

## WING LIFT CYL. ST15 / ST10

ST15-C3120055203  
to  
ST15-C31200789311

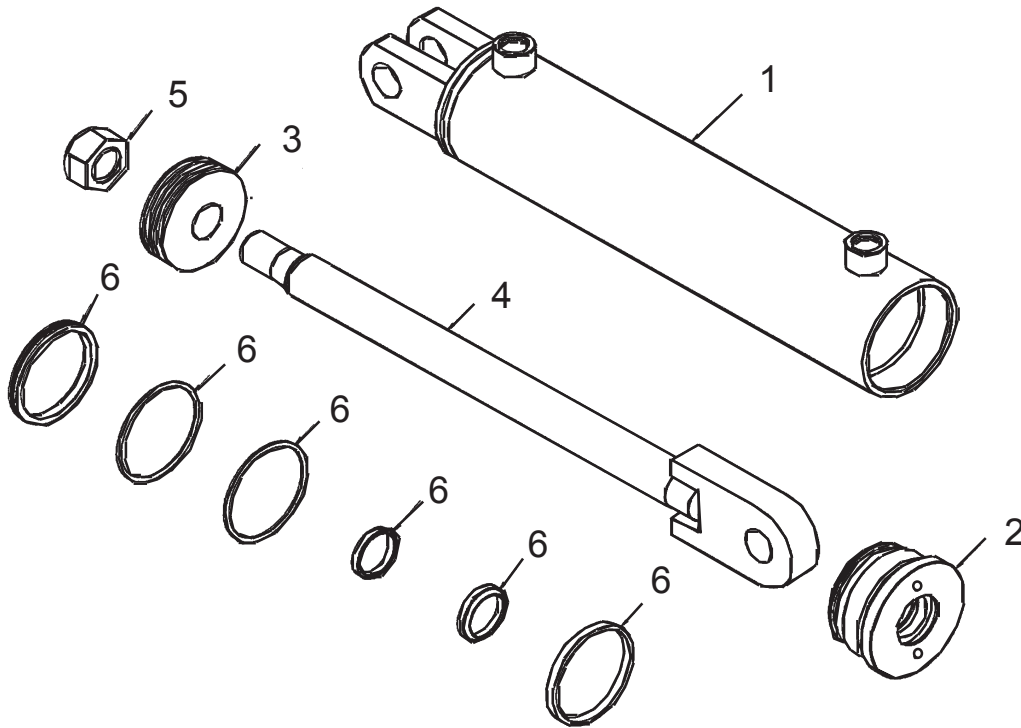

Item	Part No.	Qty.	Description
	02978614	--	Cylinder Asy. 3" Bore X 12" Stroke
1	02978645	1	Barrel Weldment
2	02978646	1	Cylinder Head
3	02978647	1	Piston
4	02978648	1	Rod
5	02030300	1	Locknut
6	02978649	1	Seal Kit

Nov. 2003  
to  
Current

## WING LIFT CYL. ST15 / ST10

ST15-C31200790311  
to  
ST15-Current

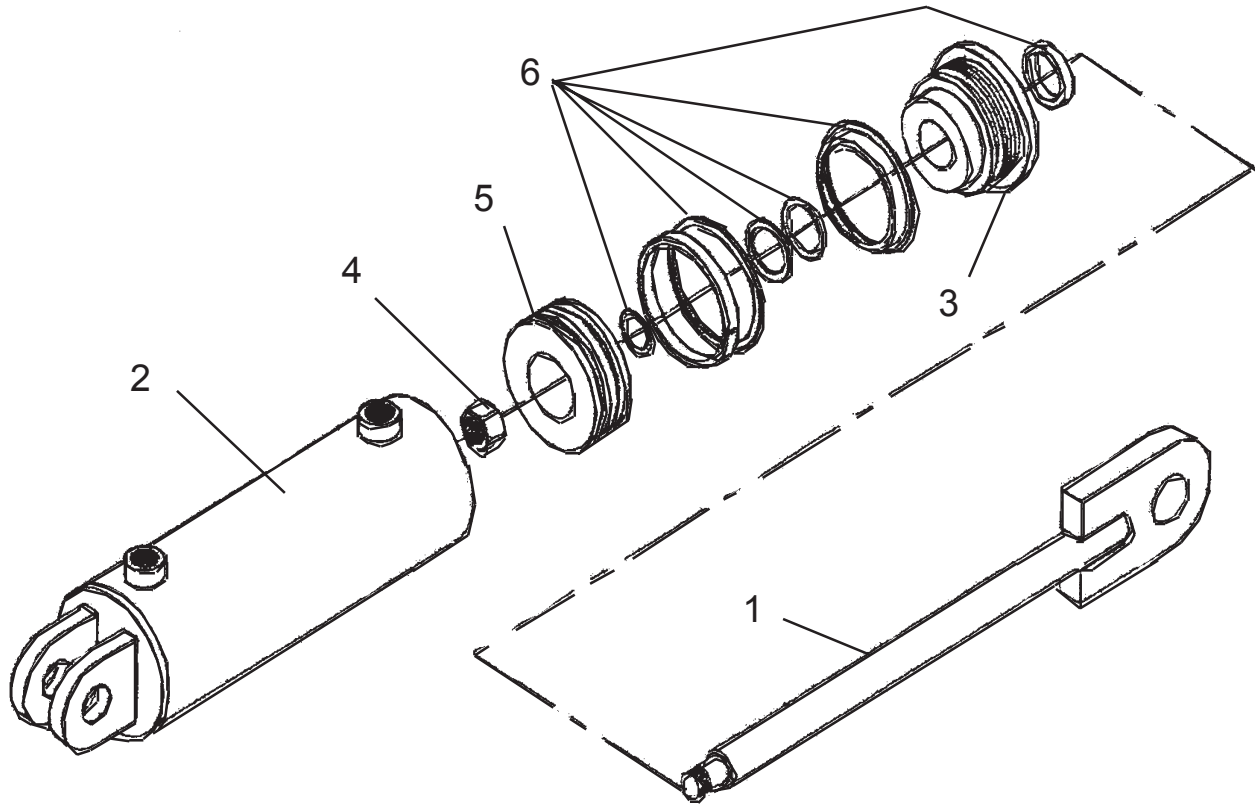

Item	Part No.	Qty.	Description
	02980472	--	Cylinder Asy. 3" Bore X 12" Stroke
1.	02980473	1	Rod
2.	02980474	1	Barrel
3.	02980475	1	Gland
4.	02980476	1	Piston Nut
5.	02980479	1	Piston
6.	02980478	1	Seal Kit

Jan. 2002  
to  
Current

# HYD. VALVE ST15 / ST10

ST15-C3120057203  
to  
ST15-Current

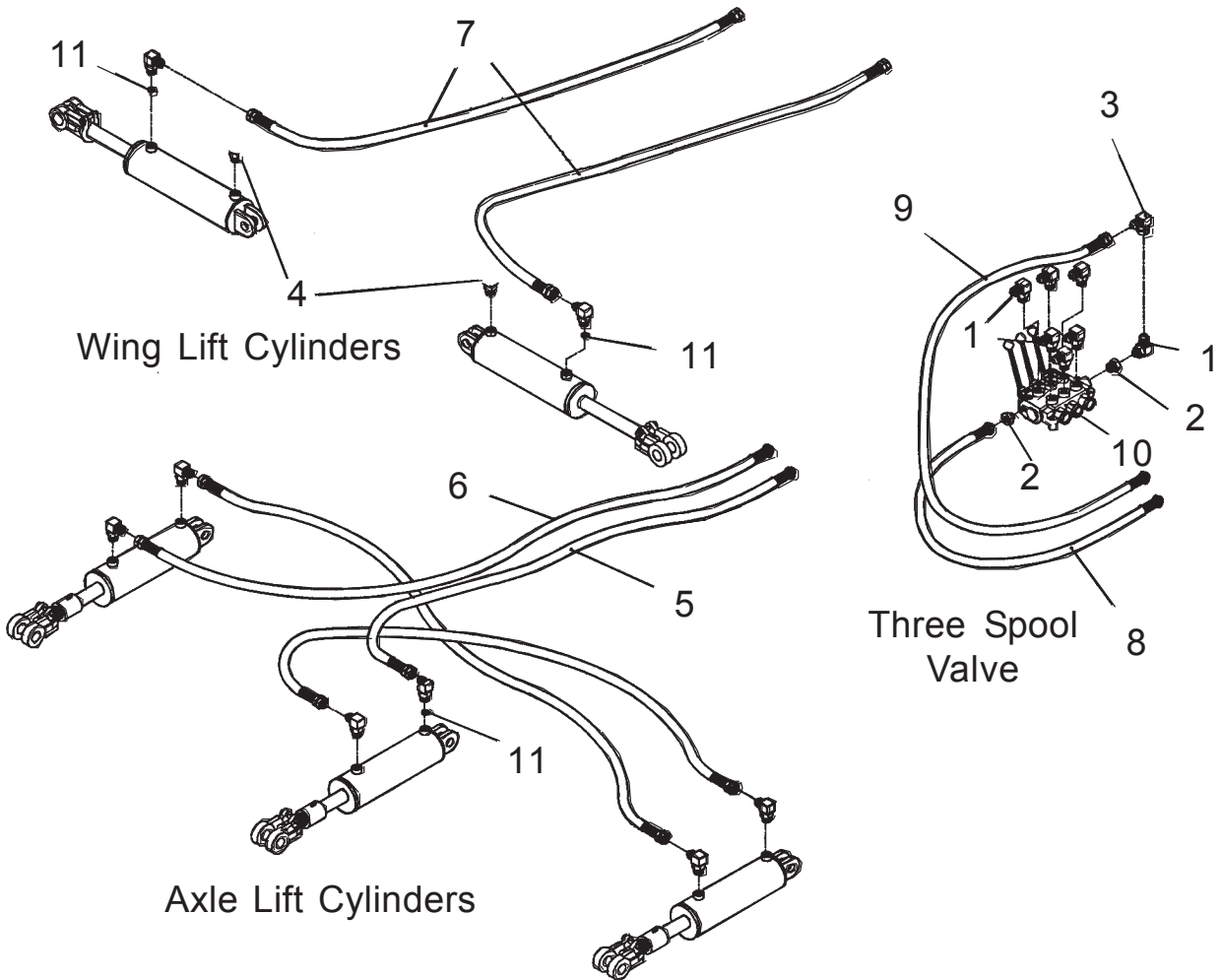

Item	Part No.	Qty ST15	Qty ST10	Description
	02978898	1	--	Spool Valve Kit, ST 15
	02978938	--	1	Spool Valve Kit, ST 10
1	02978939	7	5	Elbow
2	02978940	2	2	Reducer
3	02978941	1	1	Elbow
4	02978615	2	1	Breather, Filter
5	02978942	1	1	Hose Asy.
6	02978943	1	1	Hose Asy.
7	02978944	2	1	Hose Asy.
8	02978945	1	1	Hose Asy.
9	02978946	1	1	Hose Asy.
10	02978947	1	1	Valve, 3 spool
11	02978618	3	2	Restrictor

Jan. 2002  
to  
Current

## WING CYL. ADJUST ST15 / ST10

ST15-C31200557203  
to  
ST15-Current

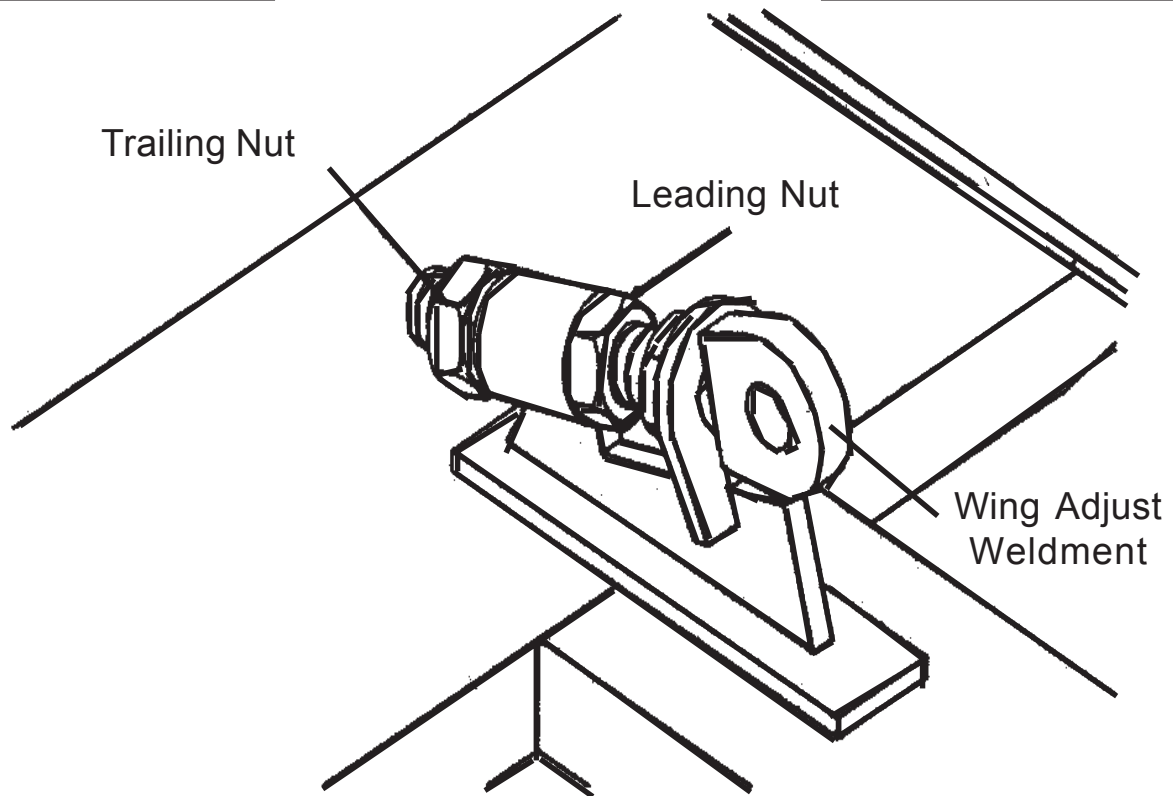

### WING AXLE & CYLINDER LEVELING

The Wing Cylinder attachments may need adjusting to level the Wing Axle to the Center section Axle. These parts are listed in the Deck Component Section of parts manual.

Leveling will require that the mower is placed on a level surface with the full weight of the mower on the tractor Draw Bar. The Cylinders must be connected and Bled. Lower the Wings into the mowing position.

Locate the front to rear leveling rods (Control Rods), these are the rods that run from center Axle to the Tongue. Adjust the control rods to level the mower from front to rear (on the center section deck). Tightening (shortening) these control rods will raise the front. Lengthening these control rods will lower the front. Mower work best when the front is approx 1" lower than the rear. IMPORTANT that these control rods are tighten equal to where they carry equal load. This can be check by tapping rod with a hammer and listening to the tone. A loose control rod will have a dull sound compared to the tight one, tighten till they both sound the same.

Adjust the Wing Axle Cylinder attachemnt. This will level the Wings with the center section Left to Right. The Wing Adjus Weldment shown above is used for this. The Trailing Nut and the Leading Nut will have to be moved together, as one is loosened the other will have to moved. Moving adjust Weldment out will raise the wing and moving it in will lower the Wing. When done make sure that both Nuts are tightened down.

# DOUBLE CHAIN CHAIN GUARDS ST15 / ST10

1. Only Double Chain Guards are available.
2. 9 Link sections of Chains are used and are hung by the 5 th link to form the double Chain Guard. (See illustration below)
3. The Cables are laced through the Bottom Link of the Chain and then a Cable Clamp is placed at each end of the Cable. (See illustration below).
4. Front Center Section is in 3 pieces, 1 center (19 Chains) and 2 outer (16 Chains ea.)
5. The Front Wings are 2 pieces (29 Chains ea.) on each wing, same LH or RH. There are two Chain Sections that bolt to a lug on the outer side of each wing.
6. The Rear Center is in 2 pieces (24 Chains ea.) which are both the same LH or RH Center.
7. The Rear Wings use 3 pieces, The center and inner Wing piece are the same (19 Chains ea.), the outer for the wings is different (18 Chains)
8. The Chains are held in with a steel rod that is welded to the chain guard bracket. to change or install chain sections these rods should be replaced and rewelded.

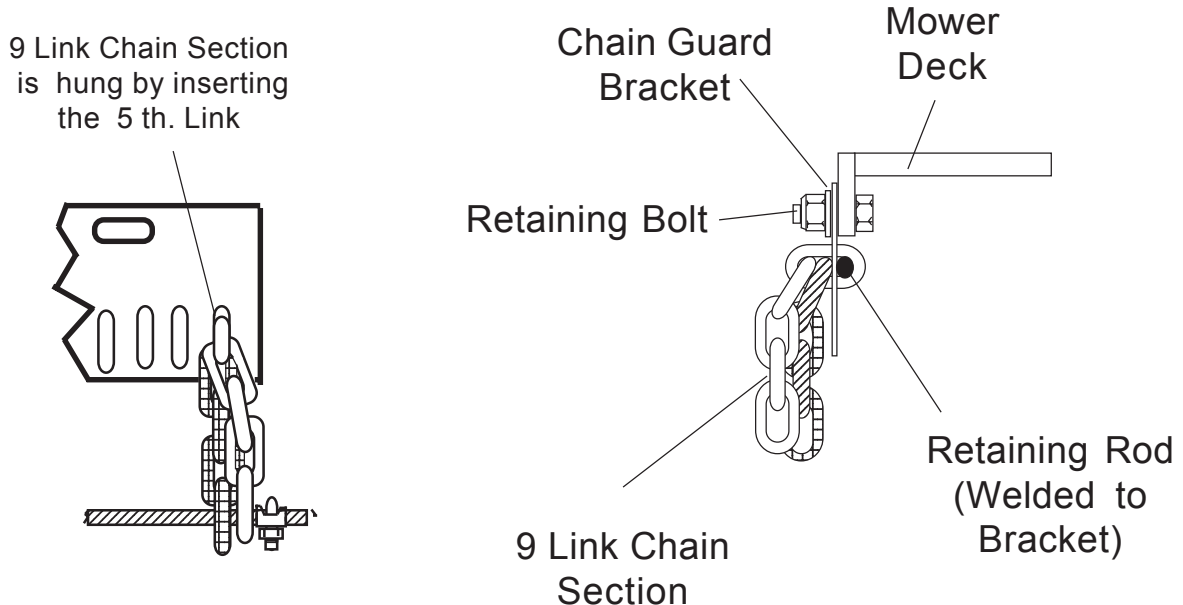



Jan. 2002  
to  
Current

## CHAIN GUARDS Front & Rear ST15 / ST10

ST15-C31200557203  
to  
ST15-Current

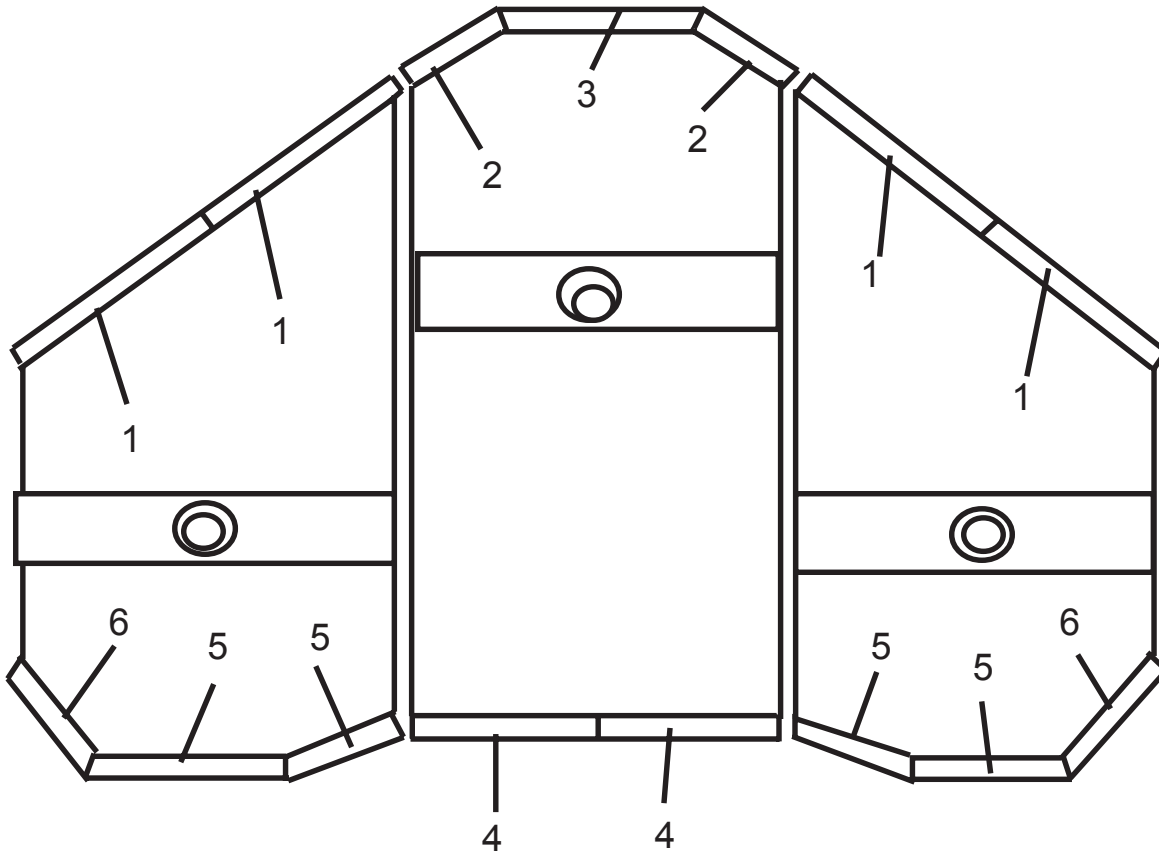

### FRONT & REAR DOUBLE CHAIN GUARD ASSEMBLIES

Item	Part No.	Qty.	Description
1.	02978586	4	Chain Guard Asy. Front Wing
2.	02978587	2	Chain Guard Asy. Front Center Outer
3.	02978588	1	Chain Guard Asy. Front Center Middle
4.	02978589	2	Chain Guard Asy. Rear Center
5.	02978590	4	Chain Guard Asy. Rear Wing Inner & Middle
6.	02978591	2	Chain Guard asy. Rear Wing Outer

Jan. 2002  
to  
Current

# CHAIN GUARDS

## Front Center Section

### ST15 / ST10

ST15-C31200557203  
to  
ST15-Current

Insert 5 th. Link

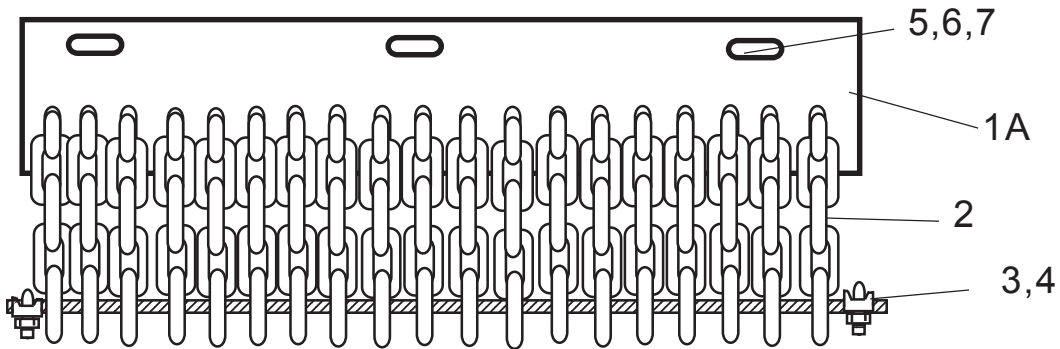
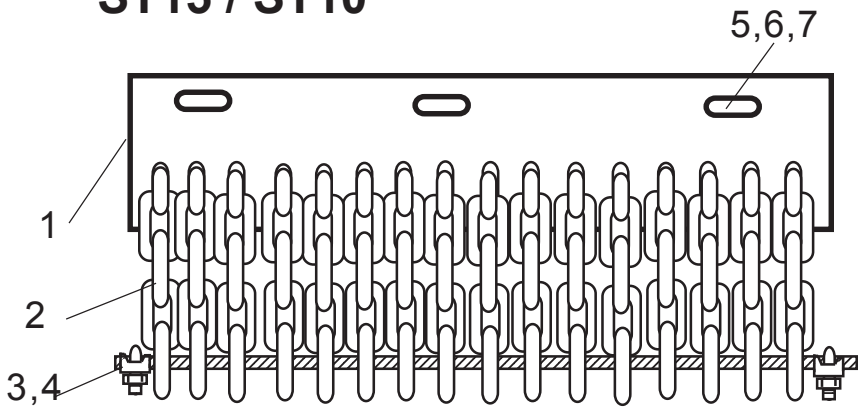
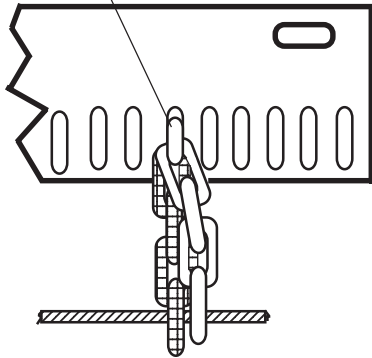

### FRONT CENTER SECTION DOUBLE CHAIN GUARDS

Item	Part No.	Qty.	Qty	Qty	Description
		Mid-cntr	L-cntr	R-cntr	
1.	02978588	1	--	--	Center Middle Chain Guard Asy. Dble Chain
1A	02978587	--	1	1	Center Outer Chain Guard Asy. Dble Chain
2.	02978592	16	19	19	Chain Link Section, 9 Links
3.	02978595	1	--	--	Cable, 22" Long
	02978594	--	1	1	Cable, 26-3/4" Long
4.	02978598	2	2	2	Cable Clamp
5.	02776600	6	6	6	Bolt
6.	15B800	6	6	6	Flat Washer
7.	00001800	6	6	6	Locknut

Qty. Shown above is all three pieces used on front center section LH, RH and Center.  
Only Double Chains Available, Cables are an Option  
Front Center section used a three piece Chain Guard

Jan. 2002  
to  
Current

# CHAIN GUARDS

## Front Wing Section

### ST15 / ST10

ST15-C31200557203  
to  
ST15-Current

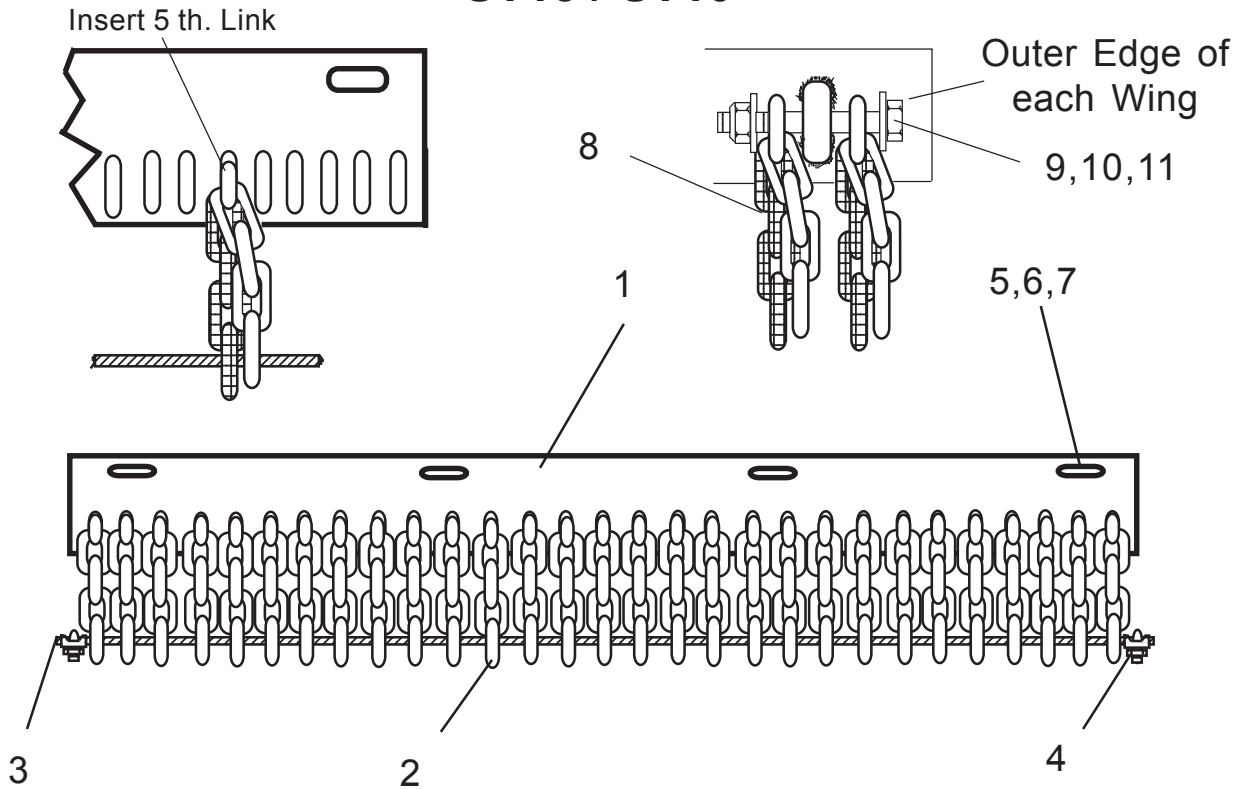

### FRONT WING DOUBLE CHAIN GUARDS

Item	Part No.	Qty.	Description
1.	02978586	2	Front Wing Chain Guard Asy. Dble Chain
2.	02978592	58	Chain Link Section, 9 Links (29 per Asy)
3.	02978593	2	Cable, 73" Long
4.	02978598	4	Cable Clamp
5.	02776600	8	Bolt
6.	15B800	8	Flat Washer
7.	00001800	8	Locknut
8.	02978592	2	Chain Link, (Bolts To Outer Wing Deck)
9.	00758068	1	Bolt
10.	15B600	2	Flat Washer
11.	00015800	1	Locknut

Qty. Shown above is for one Wing, Double Qty. for both wings  
 Only Double Chains Available, Cables are an Option  
 Each Front Wing used a two piece Chain Guard (Total 4 pieces f/ Both Wings)

Jan. 2002  
to  
Current

# CHAIN GUARDS

## Rear Center Section

### ST15 / ST10

ST15-C31200557203  
to  
ST15-Current

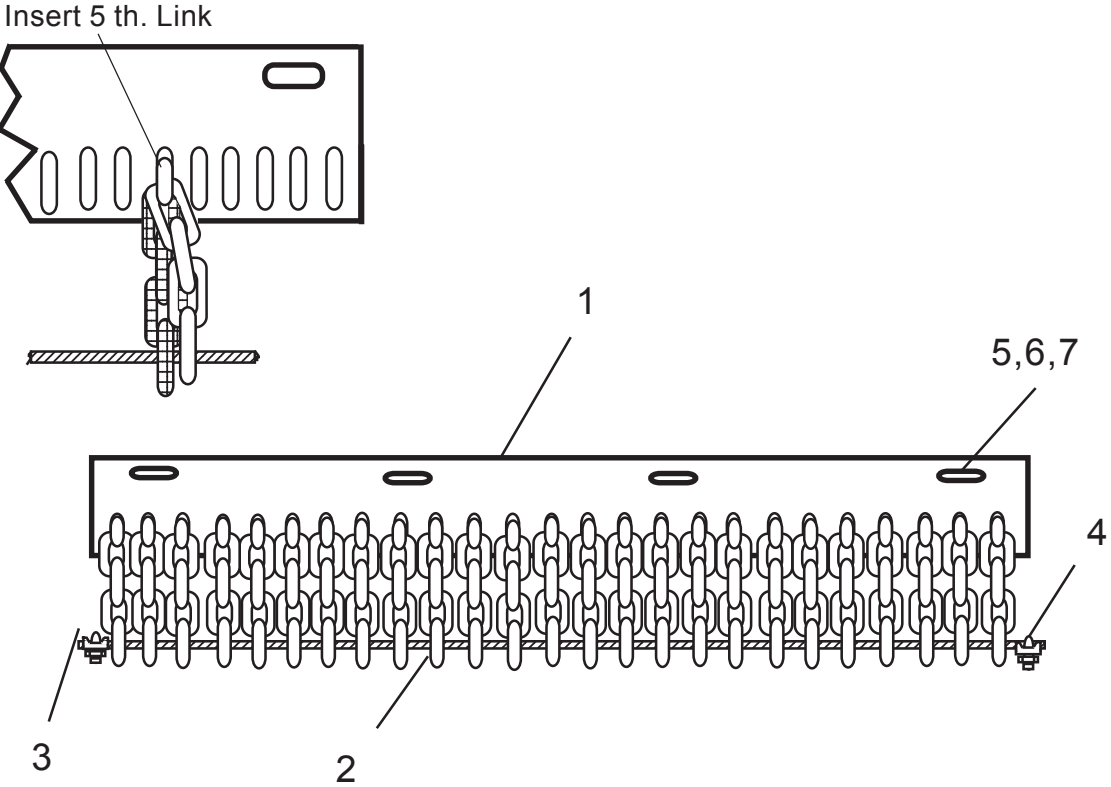

### FRONT WING DOUBLE CHAIN GUARDS

Item	Part No.	Qty.	Description
1.	02978589	2	Rear Center Section Chain Guard Asy. Dble Chain
2.	02978592	48	Chain Link Section, 9 Links (24 per Asy.)
3.	02978597	1	Cable, 62" (1 cable for both asy.)
4.	02978598	4	Cable Clamp
5.	02776600	8	Bolt
6.	15B800	8	Flat Washer
7.	00001800	8	Locknut

Qty. Shown above is for Rear Center Section,  
Only Double Chains Available, Cables are an Option  
Rear Center Section used a two piece Chain Guard (Total 2 pieces f/ L or R side)

Jan. 2002  
to  
Current

# CHAIN GUARDS Rear Wing Section ST15 / ST10

ST15-C31200557203  
to  
ST15-Current

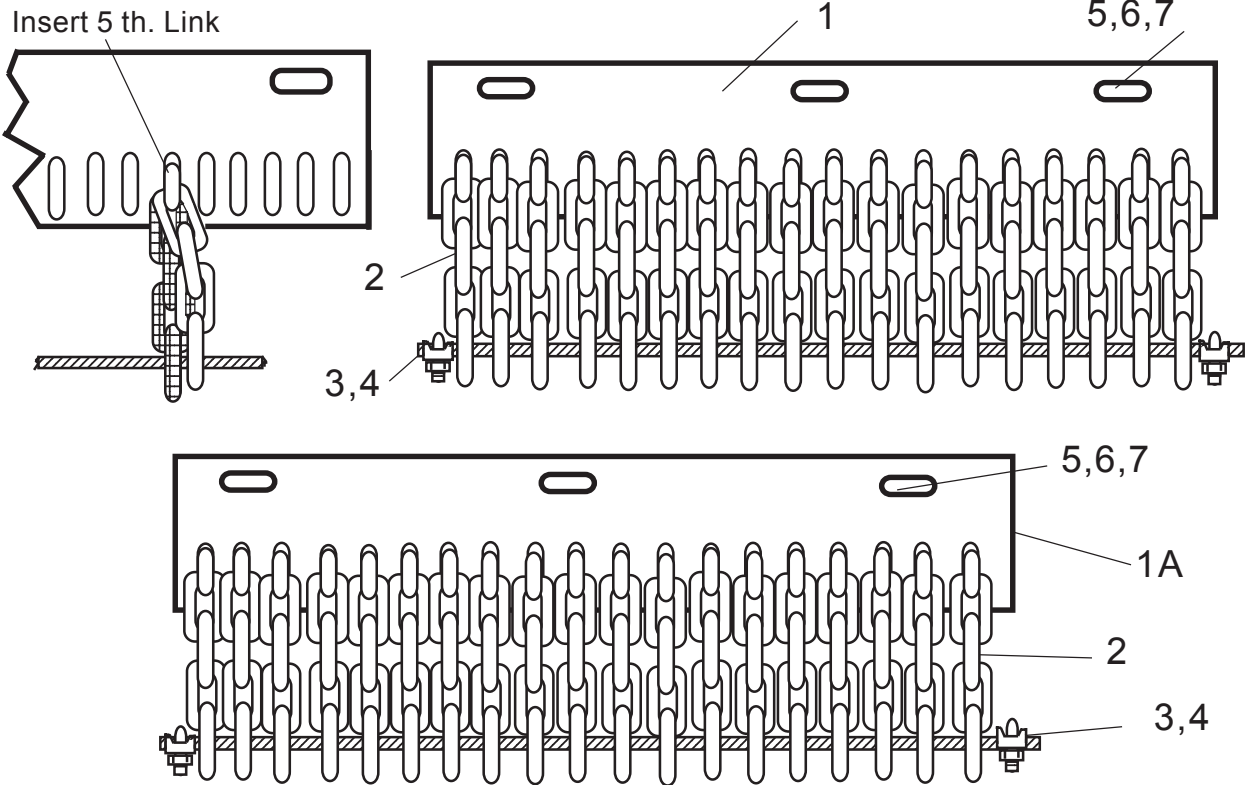

## FRONT CENTER SECTION DOUBLE CHAIN GUARDS

Item	Part No.	Qty			Description
		Inner-Wg	Mid-Wg	Outer-Wg	
1.	02978591	--	--	1	Middle & Inner Chain Guard Asy. Dble Chain
1A	02978590	1	1	--	Outer Chain Guard Asy. Dble Chain
2.	02978592	19	19	18	Chain Link Section, 9 Links
3.	02978595	a/r	a/r	a/r	Cable, 75-1/4" Long (1 cable laced thru all 3)
	02978594	--	1	1	Cable, 26-3/4" Long
4.	02978598	2	2	2	Cable Clamp
5.	02776600	6	6	6	Bolt
6.	15B800	6	6	6	Flat Washer
7.	00001800	6	6	6	Locknut

Qty. Shown above is all three pieces used on rear Wing section LH, RH and Center.

Only Double Chains Available, Cables are an Option

Rear Wing section used a three piece Chain Guard on each wing.

Jan. 2002  
to  
Current

## SAFETY CHAIN ST15 / ST10

ST15-C31200557203  
to  
ST15-Current

10,100 lbs. capacity, 59" min. length.

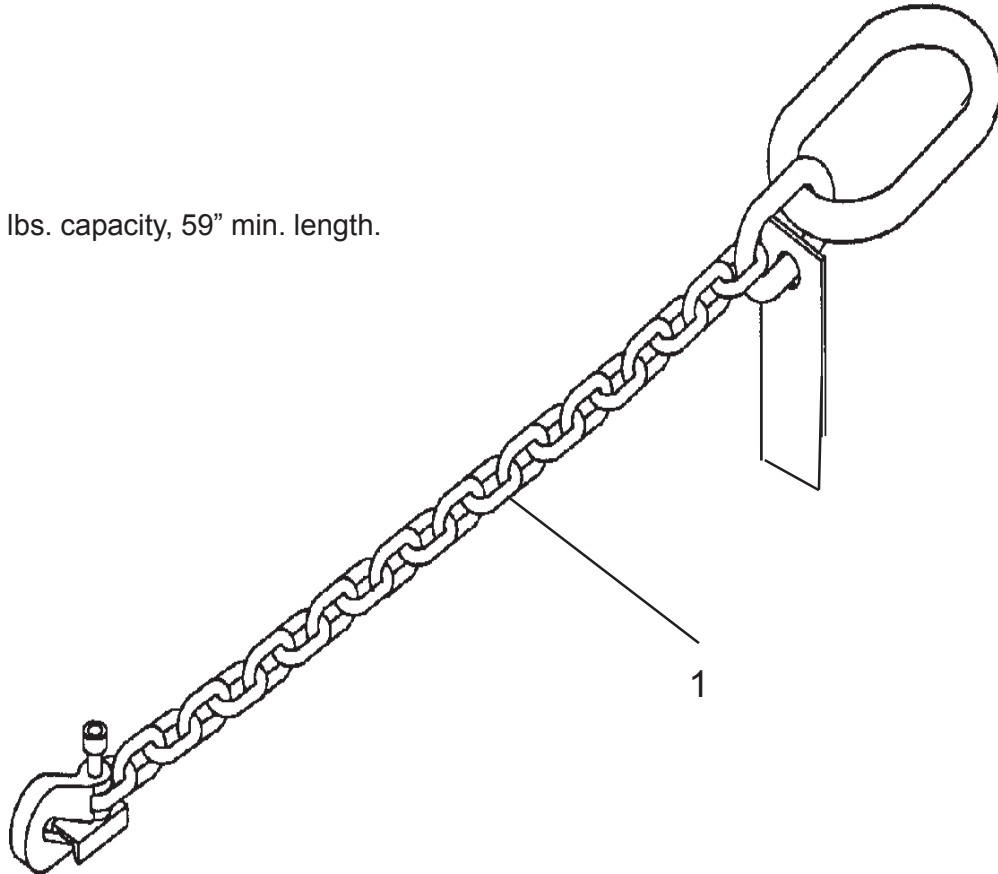

Item	Part No.	Qty	Description
1	02978778	1	Safety Chain Asy.

NOTE: This safety chain is intended as an auxiliary attaching system per ASAE S338.3. The safety chain will help control the rotary cutter should it accidentally separate from the drawbar. Do not use the safety chain for towing. Replace the entire chain if any link or end fitting is broken, damaged or stretched.

Jan. 2002  
to  
Current

# TRANSPORT LIGHT KIT ST15 / ST10

ST15-C31200557203  
to  
ST15-Current

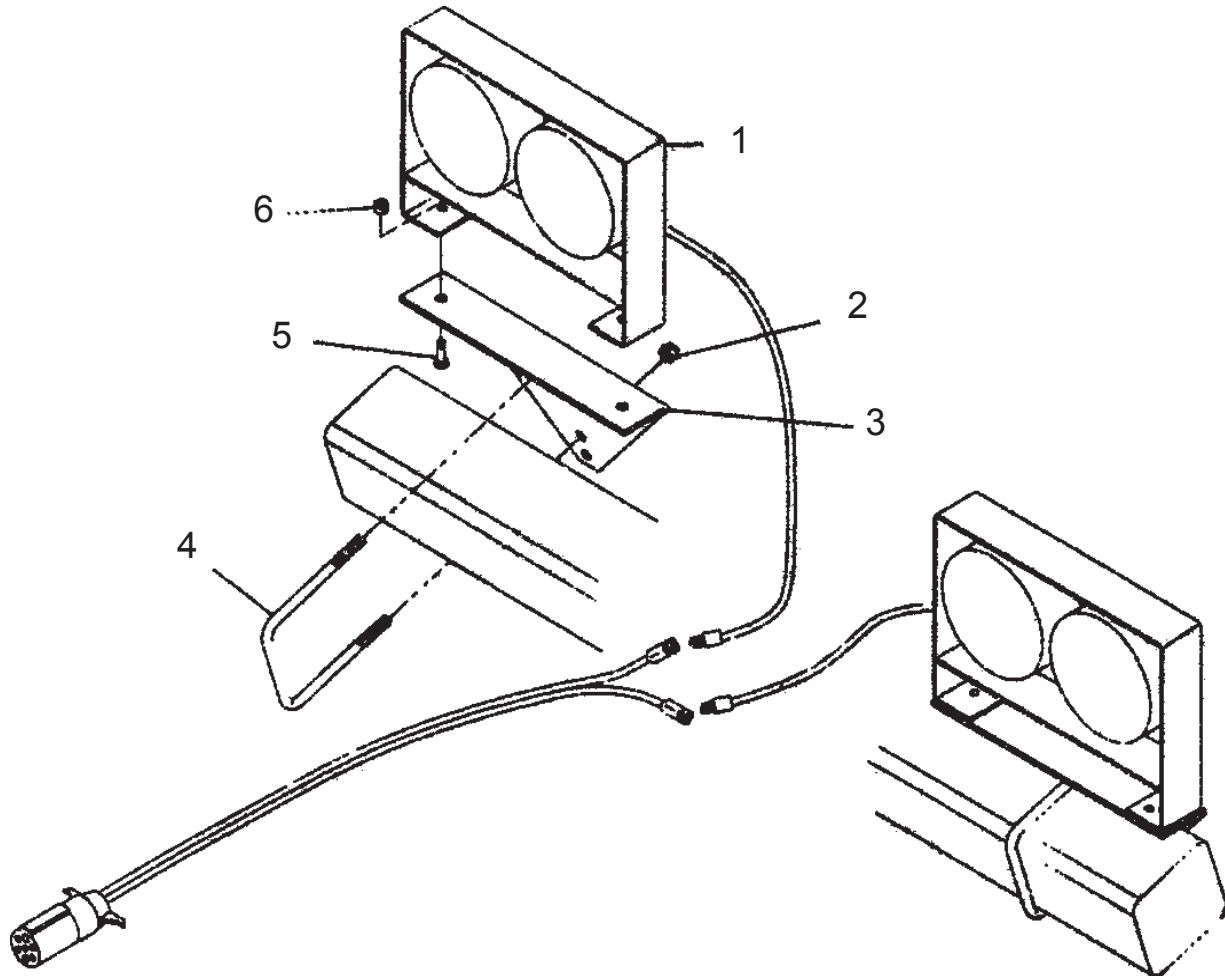

Item	Part No.	Qty	Description
	<b>02978779</b>	--	<b>Transport Light Kit (item 1 thru 6)</b>
1	02979714	1	Transport Light Set, w/ Harness
2	00015800	4	Locknut
3	02979715	2	Light Bracket
4	02979716	2	U-Bolt
5	00035900	4	Bolt
6	02030300	4	Locknut

Includes a 7-pin ag plug, wishbone harness and left and right hand dual lights.

The lights are to be mounted with the red and amber facing to the rear with the outside, or in a vertical installation, with the amber on top. The wiring harness is pre-wired with the 7' leg to attach to the left side light, and the 4' leg to attach to the right side light.

# NOTES







**ST15 Archive Manual  
Production  
Jan. 2002 (Start) S/N ST15--C31200557203  
to  
Current S/N ST15-Current  
Manual P/N 02980337**

ST15 (Archive Manual) 01/04

---

© 2004 Alamo Group Inc.